

Service
Service
Service



Service Manual

TABLE OF CONTENTS

	Page
Location of PC Boards & Versions Variation	1
Specifications	2
Safety Instruction	3
Software Upgrade Instruction.....	4
Troubleshooting.....	5
Disassembly Instructions	6
Set Block Diagram.....	7
Set Wiring Diagram	8
Circuit Diagram & PCBA Layout.....	9
Set Mechanical Exploded View	10
Revision List.....	11

© Copyright 2014 WOOX Innovations Limited.

All rights reserved. No part of this publication may be reproduced, stored in a retrieval system or transmitted, in any form or by any means, electronic, mechanical, photocopying, or otherwise without the prior permission of WOOX Innovations. Philips and the Philips' Shield Emblem are registered trademarks of Koninklijke Philips N.V. and are used by WOOX Innovations Limited under license from Koninklijke Philips N.V.

PCB Locations



VERSION VARIATIONS

Type / Versions		BDP2305				
		/F7	/I2	X77		
Board in used	Service Policy					
MAIN BOARD		M	M	M		
PF BOARD		M	M	M		
LOADER		M	M	M		
WIFI MODULE		M	M	M		
* Tips:		C -- Component Lever Repair M -- Module Lever Repair				

1 Electrical Specifications

1.1 Mains Voltage / Mains Cord

Stroke Version	Voltage	Frequency	AC Cord Type
/12	220V-240V	50Hz	VDE 2-pins round
/51	220V-240V	50Hz	VDE 2-pins round
/55/78	100V - 240V	50Hz, 60Hz	INMETRO 2-pins round mains cord (INMETRO-to-2-pins flat adaptor to be included)
/93	100V - 240V	50Hz, 60Hz	2-pins flat
/96	100V - 240V	50Hz, 60Hz	Taiwan Plug (CNS 690 approved)
/98	100V - 240V	50Hz, 60Hz	VDE 2-pins round Taiwan Plug (CNS 690 approved)
/F7	100-127V,	50Hz, 60Hz	UL/ETL Plug, 2-pins flat

1.2 Mains Voltage Variation

Destination	Main Voltage [V]/ Tolerance [%]	Range	Frequency [Hz]
Europe	230 V \pm 15%	196V to 264V	47 Hz to 53 Hz
USA	120 V -20% / +10%	96V to 132 V	57 Hz to 63 Hz
Wide	120 V -20% / 230V +15%	96V to 264 V	47 Hz to 63 Hz

1.3 Mains consumption

Player must

- Register with and conform to Energy Star Commission;
- Conform to Directive 2005/32/EC (Commission Regulation EC No. 1275/2008).

In addition, the player must conform to the following requirement.

Function	Requirement
1. Standby	<0.5W
2. Operational	10W \pm 10% (only playing disc and HDMI output) 11W \pm 10% (with 1 \times 500mA from USB and wifi module)

1.4 Power On/Off Disturbances

>-52 dB suppression of the disturbance with regard to the rated output voltage.
The peak level has to be measured according to IEC 60651 weighted (A) curve.

1.5 Additional Requirements for India

1.5.1 VoltageRange Check

The set should work NORMALLY at mains voltage from 170V to 280V AC. (Incases of set with Audio amplifiers, at lower mains voltages, audio rated poweroutput might be lower against the specified power at nominal mains voltage, butremaining performance should be unaffected).

1.5.2 Soak Test

The set should be tested in ON condition with full loaded condition (MaximumAudio Power Output in case of set with Audio Amplifiers) at mains voltage of 280VAC, for 4 hours.

1.5.3 310V AC Test

The set should be connected to 310V AC in Standby condition for 4 hours. Setshould work NORMALLY after the test.

1.5.4 Immunity to Electrical Surge from External Devices (For India & ALL other Regions)

The product shall withstand Surge from external devices (e.g. TV) cinch connectors into ALL video outputs without damaging any electrical component (e.g. MPEG IC)
All products shall have surge protection implemented for all Video Output terminals.

Test Condition:

1. Refer to ESD test setup and test condition to simulate the surge from external devices.
2. Contact Discharge to signal pin of cinch socket with below modified cinch connector jig to tap out the signal line.



Requirement:

For India: Set must be able to withstand up to $\pm 25\text{kV}$ contact discharge without any component damage.

For All Other Regions: Set must be able to withstand up to $\pm 15\text{kV}$ contact discharge without any component damage.

1.5.5 Immunity to DC Voltages from External Devices at CVBS Terminal (For India Only)

The CVBS video output must be DC isolated from external devices (e.g. TV and RF Modulators).

2 Mechanical Specifications

2.1 Mechanical Strength and Ease of Control

2.1.1 Mechanical Strength

Set exterior parts such as lens, buttonsetc, shall be able to withstand a force of 50N during 30 seconds from all possible directions. The rigid test finger, according to IEC60065 clause: 9.1.8 should be used.

Set shall be proof against a pinch force of 150N, loaded by a bare hand. The product shall give a rigid impression and shall not produce any annoying mechanical noise.

2.1.2 Rigidity of Top Surface

Set top must be able to withstand a force of 100N for duration of at least 30 seconds.

This force has to be applied by means of a flat plane of 4cm²(a plane with dimensions of 2cm x 2cm) at all places at the top side.

2.1.3 Regularity of Operating Forces for Touch Control

Deviations in the regularity of the operating force of touch control shall not be perceptible by hand.

2.1.4 Moving of Set during Operation

Set shall not move (slide backwards) whilst operating the touch control on the set or inserting disc.

2.1.5 Maximum Temperatures

The maximum permissible temperature rises of the various external parts of a product are mentioned in the next table.

The values of the temperature are based upon the maximum ambient temperature of 35°C.

The temperatures have to be measured after an operation time of 4 hours.

Maximum temperature rises with respect to the max ambient temperature.

External Product Parts	Maximum Temperature Rise (°C)
Metallic Parts:	
-front part of enclosure	10
-other parts of enclosure	25
Non-metallic Parts:	
-enclosure	30

2.2 Detachable Mains Cord & Connector Sockets

2.2.1 Connector / Socket

- a) Cinch sockets need to withstand a force of at least 100N in insertion and withdrawal directions and 50N parallel to the set surface at 2cm distance.
- b) If the connector socket is mounted directly on the PCB, the solder points have to be relieved mechanically.
- c) Connector / socket have to withstand the following minimal insertions and withdrawals,
 - USBPort: 1500
 - Other connectors: 500

2.2.2 NA

- a) Detachable mains cord inlet has to withstand minimal 2500 insertions and withdrawals.
- b) Mains cord operating force should be within the following limits:
 - Withdrawal Force, P: $10\text{N} \leq P \leq 50\text{N}$
 - Insertion Force, F: $F \leq 50\text{N}$

2.3 Visibility of User Interface Displays & Indicators

NA

2.3.1 Viewing Angle

The visibility of display is possible under a viewing angle of 30° from Top, Bottom, Left and Right.

Note: Viewing angle with regard to the perpendicular at the front of the apparatus.

2.3.2 Display illumination

The display / segment illumination should be uniform without undesirable light concentrations.

2.3.3 Brightness

As per reference. BDP2100.

2.3.4 Light Leakage

No light leakage is allowed (e.g. at connector sockets).

Above to be judge in dark condition to a bright condition of 600-800 lux

2.4 Screw Fixations

The screw fixations have to be designed in such a way, that after 10 times screwing and unscrewing, no decrease of the quality of the fixation occurs.

The dimensions of thermoplastic bosses, intended for screw-fixations, have to be designed in such a way that no deterioration of the fixation can take place, taken into account the environment conditions.

2.5 Support Foot

2.5.1 Type of material

Refer to MUS [3] for the type of material used.

1. Material for the support foot cannot shrunk in such a degree, e.g. after the Cyclic Humidity Test of 21 x 24 hours, that the set touches the furniture or other equipment during shifting. Minimum of 1mm height should still be attained.
 2. Material of the support foot cannot leave stains on furniture surfaces after climatic tests e.g. 70deg x 96hr.
 3. The support feet shall prevent the set from moving over the underneath surface while normally operating the set.
-

2.6 Touch Control Criteria

- NA

2.7 Bezel and Tray loader design

2.7.1 Strength

Permissible load on Bezel in any direction is $\geq 50\text{N}$. The Tray & Bezel should not be broken or permanently deformed, nor cause damage to other parts of set. The Bezel may dislodge above 30N without suffering any damage, and the user must be able to easily put the Bezel back. Dislodge of the Bezel shall not cause damage to the set.

2.7.2 Actuating force needed for Tray

Force needed to actuate the tray should be $\leq 5\text{N}$.

2.7.3 Tray Movement Cycle (Life Test)

24,000 open / close cycles

2.7.4 Tray Dimension

Refer to Appendix A. Disc should be fully out at tray open position.

2.8 Shock Sensitivity

Requirement:

No muting, pop sounds, picture freeze/jerk or audible/visible interference when impacting with force of -

- **In the $\pm X$ and $\pm Y$ directions:** $F \geq 6g / 3\text{ms}$, $\Delta V = 0.06\text{ms}$
- **In the $\pm Z$ direction:** $F \geq 4g / 3\text{ms}$, $\Delta V = 0.04\text{ms}$

where g = acceleration due to gravity

Refer to ODM Quality & Reliability handbook [6] for the details of the test discs and testing method.

2.9 Thermal Performance

Requirements:

1. Set should function normally
2. Temperature rise of PCB prints shall not exceed 85°C
3. Temperature readings of all mechanical / electrical components and modules shall not exceed their specification limits. The calculated junction temperature of semiconductors shall also not exceed spec limits.

Refer to "ODM Quality & Reliability handbook [6] – Thermal Stability Test for player" for the details of the testing method.

2.10 Dust Injection Test

Refer to "ODM Quality & Reliability handbook [6] – Dust Test" for details of the dust specifications and test procedures.

2.11 Noise Specifications

Test Conditions:

Measurements are to be made inside an Anechoic Chamber (echo-free environment) with ambient noise of less than 16dBA.

Measurements are to be taken at the following positions:

- (a) Top-Surface and at center of Front-Cabinet
- (b) Front-Surface and at center of Front-Cabinet

The microphone is to be positioned **10cm** from abovementioned surfaces.

Set Functional State		Requirement
Idle State	Standby Mode	< 20 dBA
	Set On and "No Disc" mode	< 20 dBA
Disc Load/Unload	Start/End peak noise	< 60dBA
	Disc loading noise (RMS)	< 45dBA
Playback CDDA & SACD (Stereo & Multichannel)	Stop to Play peak noise	< 35 dBA
	Play (first & last tracks)	< 30 dBA
	Search Forward & Backward (all speeds)	<35 dBA
	Pause (first & last tracks)	< 30 dBA
	Jump Forward (first to last track)	< 45 dBA
	Jump Backwards (last to first track)	< 45 dBA
Playback CD Unbalanced (10g/mm)	Play (first & last tracks)	< 30 dBA
Playback DVD Unbalanced (10g/mm)	Play (inner & outermost title)	< 32 dBA
Playback BD Unbalanced (7g/mm)	Play (inner & outermost title)	< 37 dBA
Playback DVD & DVD+R/RW	Stop to Play peak noise	< 35 dBA
	Play (inner & outermost title, Layer 0)	< 30 dBA
	Search Forward & Backward (all speeds)	< 35 dBA
	Pause (inner & outermost title, Layer 0)	< 30 dBA
	Jump Forward (inner to outermost title)	< 45 dBA
	Jump Backwards (outer to innermost title)	< 45 dBA
	Layer Jump (layer 0 to layer 1)	< 45 dBA
Playback BD & BD-J	Stop to Play peak noise	< 44 dBA
	Play (inner & outermost title)	< 36dBA
	Search Forward & Backward	< 36dBA
	Pause (inner & outermost title)	< 36dBA
	Jump Forward (inner to outermost title)	< 44 dBA
	Jump Backwards (outer to innermost title)	< 44 dBA
Playback BD-9	Stop to Play peak noise	< 47 dBA
	Play (inner & outermost title)	< 46 dBA
	Search Forward & Backward	< 46 dBA
	Pause (inner & outermost title)	< 46 dBA
	Jump Forward (inner to outermost title)	< 47 dBA
	Jump Backwards (outer to innermost title)	< 47 dBA

2.12 Finishing / Artwork Reliability

2.12.1 General Appearance / Finishing (NA)

Refer to OQA Cosmetic Criteria for details.

The visibility of flow lines, sink marks, scratches, unevenness and flashes has to be judged at a distance of 30 cm, with normal overhead lighting (800–1000 lux):

Surface Area	Requirements
For highly visible surfaces	Very high appearance requirements: ✓ None or very small flow lines ($\leq 5\text{mm}$) may occur ✓ None or very small and faint injection-marks / sink-marks may occur ✓ No burrs, scratches or other defects may be visible
For surfaces which in normal use are not or less visible	High appearance requirements: ✓ Small flow lines ($\leq 10\text{mm}$) may occur ✓ No burrs, injection marks, sink marks or other defects may be visible

The exterior of the apparatus should be free of burrs.

Sharp edges and corners should have a minimum radius of 0.3mm whenever possible.

2.12.2 Decorative Coating Test

Samples need to be sufficiently aged before testing. They should be prepared according prescribed production conditions and conditioned at standard atmospheric conditions for at least 3 weeks. However if the samples are prepared within 3 weeks before testing, artificial aging in an oven at 40°C during 3 x 24 hours is required. The samples should be allowed to stabilize at the standard atmospheric conditions after the ageing period and before executing the tests (in general a period of 2 hours will be sufficient).

2.12.2.1 Adhesion Test

Test methods are divided into:

a) Destructive test

This test is intended for the release of coating and printings. For this method, preparation is done using a knife is used to cut gridlines over the area to be tested. The gridlines should be approximately 2mm spaced.

b) Non-destructive test

This test is intended for incoming inspections of batches of products with coatings and printings.

Test Method (for both destructive and non-destructive)

Press the self-adhesive tape with a length of about 5 cm firmly onto the sample, and remove it *immediately with a jerk* at an angle which is as close as possible to 60° to the surface. Corners and sharp edges have to be included in this test.

2.12.2.2 Resistance to Ethanol

Test method

The coating is rubbed in groups of 10 or 25 rubbing cycles (one cycle = one complete to and from movement) with the hand tool with an average speed of 2 m/min. In the case that more than 25 cycles are required, the felt has to be soaked after each 25th cycle with Ethanol by means of a diffuser and the test should be continued immediately. After the last test cycle rests of the Ethanol has to be wiped off immediately from the tested surface with a soft cloth. (See figure)

Requirement: Rcs3 = 2x25 cycles

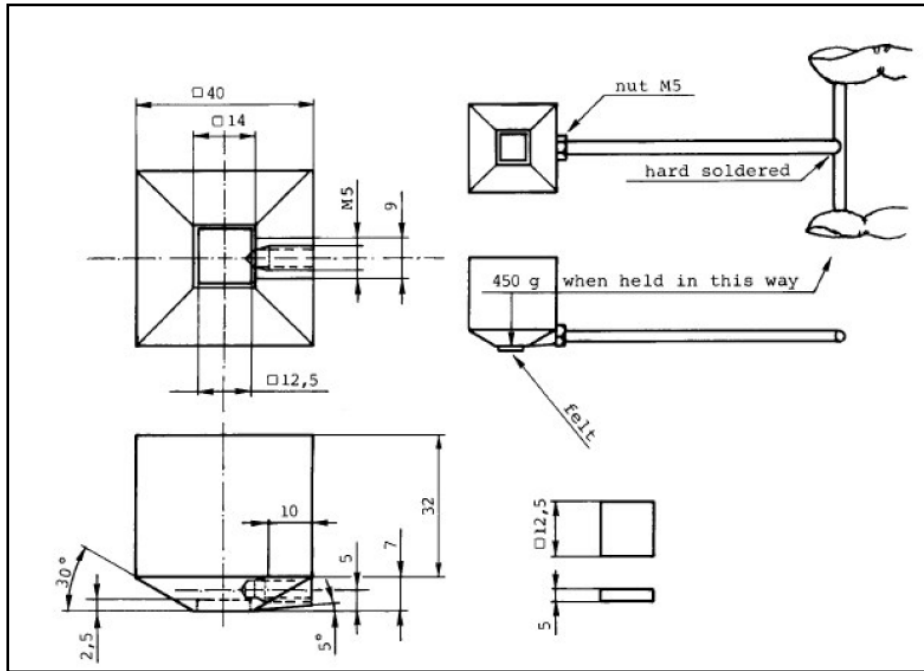

2.12.2.3 Resistance to Dry Abrasion

Test method

A fixed load of 2.5 N is used for this method. The specific pressure depends on the size of the area to be tested. This implies, in relation to real use in practice, a higher load on ribs, raised lettering, etc. The abrasive wheel is made from 3 discs of abrasive material (Scotch Brite Cleaning and finishing material type A-VFN, thickness 6.35mm).

Requirement: Rda2 = 175Rev

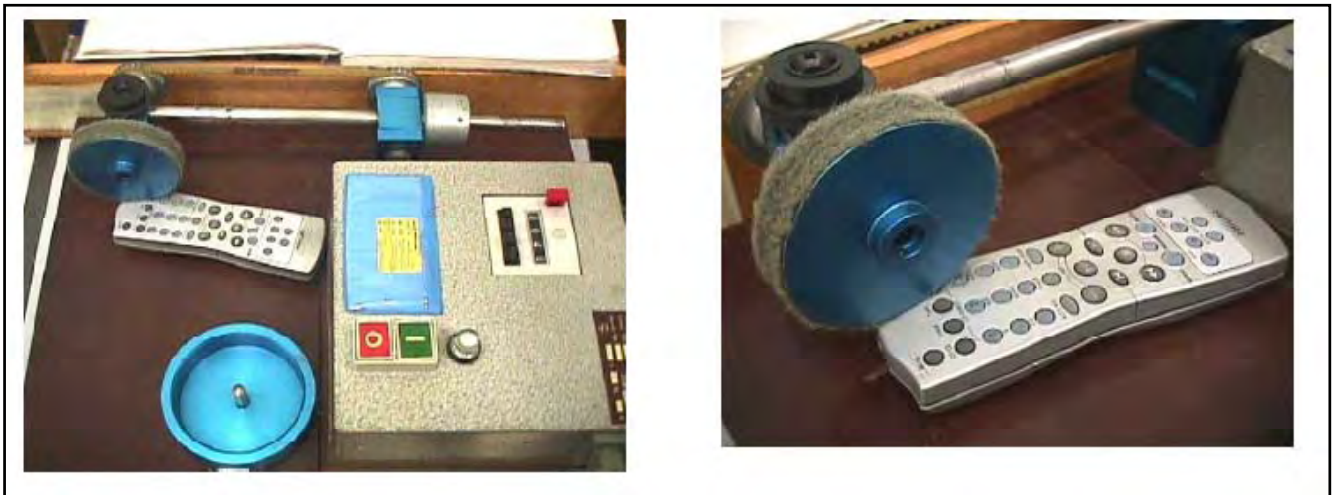

2.12.2.4 Scratch Resistance (Scr)

Test method:

Test Roller used: Steel

Tester Position: Tester should be placed vertically with both rubber wheels on the test substrate

Average Speed: Very slow (2 m/min)

Test Pattern: 2 perpendicular to each other

Number of Stroke: 10cm (centre 6cm for assessment)

Mutual Distance between strokes: approx 1cm

Load Applied: 10N

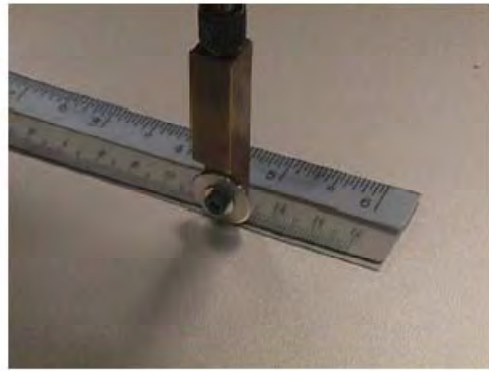

- To get a better insight in the real worn effect, test have to be performed starting with a load one step lower and ending with a load one step higher then defined load.

2.13 Transportation & Handling

2.13.1 POS & Label Adhesion and Print Requirements

2.13.1.1 Label Adhesion

For Removable Labels (e.g. Point-of-Sale labels): Adhere neatly and flat on the surface and be easily removed. It must not leave residue or permanently stains the surface.

For Permanent Labels (especially Product Family Labels): Should never lift-off at the edges or form large bubbles underneath.

Tests: +70°C Dry Heat Exposure Test (4 days)
Damp Heat Storage Test (7 days)

Criteria: After the tests, the label should conform to the requirements stated above.

2.13.1.2 Label Printing

For Permanent Labels: Resistance to water and general household cleaning agents.

Test: Resistant to Ethanol- Requirement 1x25 cycles

Criteria: The printing should not deface or smudge. A slight overall lightening of the color is allowed but there should not be any portion of print removed. Wordings should remain well legible.

2.14 Transportation & Handling

2.14.1 Packaging Release Test Specifications

2.14.1.1 For All Regions EXCEPT China&India

Test	Specification
Vibrations	7Hz, 1.05g, 10.6mm (p-p), 30mins. Vibrate on 3 mutually perpendicular faces.
Normal Drop	For sets always transported in 1 direction and < 50Kg : - Drop 3x Bottom-Face according to Table A below + 10cm. - Sequence Left – Front – Right – Rear – Top at 25cm + 10cm.
Cold Drop	Set to be pre-conditioned at –10degC for at least 16Hrs. Drop according to Height Table A below + 10cm. To drop on 3 perpendicular faces per set, starting from the smallest to the largest face. Another set to be used to cover the other 3 faces.

* All packages to undergo Vibration before Drop Test.

Table A :

Mass (Kg)	Height (cm)	Mass (Kg)	Height (cm)	Mass (Kg)	Height (cm)
1	70	11	48	21	38
2	70	12	46	22	37
3	67	13	45	23	36
4	63	14	44	24	37
5	60	15	43	25	36
6	57	16	42	26	36
7	55	17	41	27	36
8	53	18	40	28 - 50	35
9	51	19	39		
10	49	20	38		

2.14.1.2 For China & India Regions ONLY

Test	Specification
Vibrations	Test (1) : 10-30-10 Hz , 0.75mm , 5 Cycles , 15mins Test (2) : 30-55-10 Hz , 0.25mm , 5 Cycles , 9 mins Fresh sets to be used for (1) and (2) above. Vibrate on 3 mutually perpendicular faces.
Bump Test	Bump Acceleration 100m/s ² , Pulse Duration 16msec No of Pulses : 1000 bumps , Bump Frequency : 60-80 bumps/min
Normal Drop	According to Height Table B below + 10cm. - Drop Bottom – Front – Left – Rear – Right – Top. - Drop 3 mutually perpendicular Edges corresponding to the corner chosen below. - Drop Corner Enough sets have to be used to confirm that the product is well-protected against drop at all 8 corners.
Multiple Drop	This is to be done immediately after the Normal Drop Drop 2x on Bottom-Face at Height of 70cm.
Cold Drop	Set to be pre-conditioned at –10degC for at least 16Hrs. Drop according to Height Table B below + 10cm. Drop Sequence as per Normal Drop Test above.

* All packages to undergo Vibration before Drop Test.

Table B:

Mass (Kg)	Face Drops	Edge & Corner Drops
1 – 9	80 cm	60 cm
10 – 19	60 cm	50 cm
20 – 29	50 cm	40 cm
30 – 39	40 cm	30 cm

2.14.2 Packaging Robustness Test Specifications

Note: To conduct this during **Design Verification Test (DVT)** phase only.

Purpose is to reveal weak points in the Product or Packaging and to take preventive actions to strengthen these points so as to ensure a more robust Product/Packaging.

The test is referenced to **ISTA-2A** standard as follows:

Mass (Kg)	Face Drops
< 9.5	97 cm
9.5 – 18.5	82 cm
18.5 – 27.5	61 cm
27.5 – 45.5	51 cm

Drop Sequence:

- Drop on 1x Corner, 3x Edges, 6x Faces
- Select the vulnerable corners (e.g. thin packaging or weak product corner)
- The 3x edges are those radiating from the chosen Corner, and to drop from shortest to longest edge
- The Faces drops should be done from the smallest to the largest face

2.14.3 Stacking Test

Condition: Reference IEC60068-2-3 Ca, Damp Heat Steady State at 40°C, 93%RH (±2%)

Duration: 1 day

Product is packed in packaging as per production

No of layer in stack: As indicated on Packaging Box graphics

Note: If simulated weight is used, a very rigid flat Plate shall be placed over a single layer of packages, and the weights shall be evenly distributed over the plate.

Test Criteria: After the test, the packaging and its content should still be in good physical condition. The polyfoam should not be severely cracked and the Cushioning-Ribs should not be over-compressed (badly-crushed).

2.14.4 Storage Test (Packed)

Tests are conducted with the sets sealed in their packaging.

Test	Test Conditions	Remarks
Dry Heat Storage	+70°C, 96 hrs	After a 4 hour recovery to Room Temp (25C) , to check the external/internal condition of the product/labels/packaging as well as basic functional.
Cold Storage	-40°C, 96 hrs	
Damp Heat Steady State	According to IEC 60068-2-3 Ca 40°C, 90%RH, 21x 24hrs	

3 Regulatory

3.1 Safety

Player shall as a minimum comply with the requirements laid down in IEC 60065:2001/A1:2005. This is applicable to all countries. However, in countries having national safety standards, which differ from IEC60065, the relevant national standards are applicable,

- For European countries: EN60065(latest addendum)
- For USA, Canada: UL60065

All Information technology equipments shall as a minimum comply with the requirements laid down in IEC60950-1:2001. This is applicable to all countries. However, in countries having national safety standards which differ from IEC60950 the relevant national standards are applicable,

- For European countries: EN60950-1:2001
- For USA: UL1950

3.1.1 Laser Safety

All products shall as a minimum comply with the requirements laid down in IEC 60825-1:1993/A1:1997/A2:2001. This is applicable to all countries. However, in countries having national safety standards, which differ from IEC 60825-1, the relevant national standards are applicable,

- For EU: EN60825-1:1994/A1:2002/A2:2001
- For USA: CDRH (Centre for Devices and Radiological Health) 21 CFR1040.10, etc.

3.1.2 Touch Current

Standard Reference: IEC 60065:2001/A1:2005

Measured in accordance IEC 60990:1999

Requirement	Test Condition
Tropical Climate: 0.35mA (peak)	<ul style="list-style-type: none"> • Ambient Temperature: Normal (25°C) • Mains Supply: Nominal Voltage & Nominal Voltage +10% • State: Power On (Any mode)
Non-Tropical Climate: 0.7mA (peak)	

3.2 Electromagnetic Compatibility

Player shall as a minimum comply with the requirements laid down in CISPR13 for emission and CISPR20 for immunity. This is applicable to all countries. However in countries having national EMC requirements which differ from CISPR 13 the relevant standards are applicable,

- Emission: EN55013:2001/A1:2003/A2:2006 for European countries
- Immunity: EN55020:2007 for European countries
- Radiated, radio-frequency, electromagnetic field immunity: EN 61000-4-3:2006/A1:2007
- Mains Harmonics: EN61000-3-2:2006
- Voltage Fluctuations and Flicker: EN61000-3-3:1995/A1:2001/A2:2005
- EMF: EN 62311:2008
- FCC15 part 15B for USA, Canada

In countries where EMC standards are not compulsorily enforced, CISPR13 must be enforced.

All information technology equipment shall as a minimum comply with the requirements laid down in CISPR22 for emission and CISPR24 for immunity. This is applicable to all countries. However in countries having national EMC requirements which differ from CISPR 22, the relevant standards are applicable,

- Emission: EN55022:1998/A1:2000/A2:2003 for European countries
- Immunity: EN55024:1998/A1:2001/A2:2003 for European countries
- Mains Harmonics: EN61000-3-2:2006 for European countries
- FCC part 15 for USA
- ETSI EN 301 489-1 v1.8.1 (2008-04) for European countries

- ETSI EN 301 489-17 v.2.1.1 (2009-05) for European countries
- ETSI EN 300 328 v1.7.1 (2006-10) for European countries

In countries where EMC standards are not compulsorily enforced, CISPR22 must be enforced.

3.3 Electrostatic Discharge Immunity

Standard Reference: IEC61000-4-2:2001

The product shall withstand electrostatic discharges on all user accessible parts.

3.3.1 Contact Discharge

Level	Voltage level General (kV)	Voltage level USA (kV)	Requirement
1	0 – 2	0 – 3	No deviations allowed
2	>2 – 4	>3 – 4	Short perceptible deviations allowed
3	>4 – 5	>4 – 5	Normal recallable function changes allowed
4	>5 – 7	>5 – 7	Resets allowed (recallable via standby/on button). No hang-ups allowed.
5		>7 – 8	No component or mechanical damage allowed.

3.3.2 Air Discharge

Level	Voltage level General (kV)	Voltage level USA (kV)	Requirement
1	0 – 4	0 – 6	No deviations allowed
2	>4 – 8	>6 – 8	Short perceptible deviations allowed
3	>8 – 10	>8 – 10	Normal recallable function changes allowed
4	>10 – 15	>10 – 15	Resets allowed (recallable via standby/on button). No hang-ups allowed.
5		>15 – 18	No component or mechanical damage allowed.

3.4 Immunity to Mains Interference / Failure

The following tests are to be done in operation (On) mode while playing a Blu-ray Disc and in standby mode.

3.4.1 Electrical Fast Transient / Burst Immunity

Standard Reference: IEC61000-4-4:2004

Performance	Requirement	Conditions
Level 1 500V	Performance criteria A	Polarity: positive / negative Angle: Asynchronous Test duration: 12 /step Step duration: 5 sec
Level 2 1000V	Performance criteria B	
Level 3 1500V	Performance criteria C	

Performance criteria:

- Criteria A: Normal performance;
- Criteria B: Temporary loss of function or degradation of performance which ceases after the disturbance ceases, and from which the equipment under test recovers its normal performance, without operator intervention;
- Criteria C: Temporary loss of function or degradation of performance, the correction of which requires operator intervention;
- Criteria D: Loss of function or degradation of performance which is not recoverable, owing to damage to hardware or software, or loss of data.

3.4.2 Mains Drop-out Immunity

Standard Reference: IEC 61000-4-11:2004

- Variation 0% (= 100% dip) at T-event = 50msec. Performance criteria B
- Variation 40% (= 60% dip) at T-event = 100msec. Performance criteria B
- Variation 0% (= 100% dip) at T-event = 1 sec. Performance criteria C

Additional for USA:

- Variation 0% (= 100% dip) at T-event = 100msec in standby mode. Performance criteria B

Performance criteria:

- Criteria A: Normal performance;
- Criteria B: Temporary loss of function or degradation of performance which ceases after the disturbance ceases, and from which the equipment under test recovers its normal performance, without operator intervention;
- Criteria C: Temporary loss of function or degradation of performance, the correction of which requires operator intervention;
- Criteria D: Loss of function or degradation of performance which is not recoverable, owing to damage to hardware or software, or loss of data.

3.4.3 Surge Immunity (Lightning Test)

Standard Reference: IEC61000-4-5:2005

The product shall withstand mains interferences of

For Europe:

Differential Mode: $\pm 2\text{kV} / 20\Omega$, Performance criteria C

Parameters: Bi-wave, Open circuit voltage: $1.2/50\mu\text{s}$, Short circuit current: $8/20\mu\text{s}$.
Range: $\pm 0.5\text{kV}$ to $\pm 2\text{kV}$, in steps of 0.5kV . 10 shots per combination. One shot per minute.
Serial impedance: 20Ω . Polarity: Positive and Negative. Phase angle: 90° and 270° .

Common Mode: $\pm 6\text{kV} / 20\Omega$, Performance criteria C

Parameters: Bi-wave, Open circuit voltage: $1.2/50\mu\text{s}$, Short circuit current: $8/20\mu\text{s}$.
Range: $\pm 3\text{kV}$ to $\pm 6\text{kV}$, in step of 1kV . 10 shots per combination. One shot per minute.
Serial impedance: 20Ω . Polarity: Positive and Negative. Phase angle: 90° and 270° .

For NAFTA:

Differential Mode: $\pm 6\text{kV} / 12\Omega$, Performance criteria C

Parameters: Bi-wave, Open circuit voltage: $1.2/50\mu\text{s}$, Short circuit current: $8/20\mu\text{s}$.
Range: $\pm 1\text{kV}$ to $\pm 6\text{kV}$ in steps of 1kV . 10 shots per combination. One shot per minute.
Serial impedance: 12Ω . Polarity: Positive and Negative. Phase angle: 90° and 270° .

Common Mode: $\pm 6\text{kV} / 12\Omega$, Performance criteria C

Parameters: Ring-wave, 100kHz ,
Range: $\pm 3\text{kV}$ to $\pm 6\text{kV}$, in step of 1.5kV . 10 shots per combination. One shot per minute.
Serial impedance: 12Ω . Polarity: Positive and Negative. Phase angle: 90° and 270° .

For others:

Follow Europe requirements.

With the following requirement,

- Apparatus should fulfill the leakage current requirements of less than 3mA after the Surge Immunity test.
- Defects or permanent deviations are not allowed.

Performance criteria:

- Criteria A: Normal performance;
- Criteria B: Temporary loss of function or temporary degradation of performance not requiring an operator;
- Criteria C: Temporary loss of function or temporary degradation of performance requiring an operator;
- Criteria D: Loss of function with permanent damage to equipment (which means failing the test).

Appendix A: Mechanical Dimensional Sketch and Tolerances

To be fixed

Appendix B: Energy Efficiency Calculation

NA

Appendix B: Energy Efficiency Calculation

NA

Appendix C: Optical Test Disc Requirement

Item	Disc type	Remarks
CD		
• Black dot: 1000 μ	TCD-726	
• Double Black dot: 600 + 300 μ	Philips Sub8A	
• Wedge: 1000 μ	Philips Sub8A TCD-726	
• Normal fingerprint: 65 μ	Philips Sub8A TCD-726	
• Heavy fingerprint: 75 μ	Philips Sub8A TCD-726	
• Scratch: 3.0mm	TCD-721R	
• Thick Disc: 1.5mm	SCD-4006	
• Thin Disc: 1.1mm	Philips Thin disc	
• Vertical Deviation: \leq 0.5mm	Philips VDD disc	
• Eccentricity: 200 μ	Philips ECC disc	
• Skew: 0.6 \leq	Philips 8cm skew disc	
• Unbalance: 10gmm	Philips SBC442 10gmm unbalance	
• Birefringence: 150 μ	SCD-4013	
• Disc Size: 8cm	MP3 Test CD 8cm (7104 099 28271)	
• SVCD 100min		
• Glass substrate	CD glass disc 33g	
CD RW		
• Low reflectivity	Philips Low reflectivity	
• High reflectivity	Philips High reflectivity	
• Black dot: 800 μ	Philips CD-RW printed	
• Normal fingerprint: 65 μ	Philips CD-RW printed	
SACD		
• SACD Hybrid: CD layer	SACD EOL (7104 099 98801)	Playback CD layer
DVD Single Layer		
• Black dot: 1100 μ	Philips CVP02.18A TDV-525 (up to 1000 μ m)	
• Double black dot: 600 μ + 300 μ	Philips CVP02.18A	
• Wedge: 1100 μ	Philips CVP02.18A	
• Normal fingerprint: 65 μ	Philips CVP02.18A TDV-525	
• Heavy fingerprint: 75 μ	Philips CVP02.18A TDV-525	
• Scratch: 3mm	TDV-521C	
• Thick Disc: 1.3mm	Philips CVP02.50	
• Thin Disc: 1.1mm	Philips CVP02.60	
• Vertical deviation: \leq 0.5mm	TDV-533C	
• Eccentricity: 150 μ	TDV-513 TDP0014	
• Skew: 0.4 \leq	Philips CVP02.40	
• Unbalance: 10gmm	Philips CVP02.19 10gmm	

	unbalance	
• Disc Size: 8cm	Philips LVP07.03	
• Substrate thickness test disc2 test disc3 test disc4	520µm 670-730µm 560-530µm	Horror Disc, no set hang up allowed.
• Birefringence: 150 µ	SVD-4010	
• Hair scratch	Philips Hair scratch test disc	
• Glass substrate	Glass CVP02.19 disc	
DVD Double Layer		
• Black dot: 1100 µ	Philips LVP11.01A TDV-545 (up to 1000µm)	
• Double black dot: 600 µ + 300 µ	Philips LVP11.01A	
• Wedge: 1100 µ	Philips LVP11.01A	
• Normal fingerprint: 65 µ	Philips LVP11.01A TDV-545	
• Heavy fingerprint: 75 µ	Philips LVP11.01A TDV-545	
• Scratch: 3mm	TDV-541C	
• Vertical deviation: _0.5mm	TDV563C	
• Eccentricity: 150 µ	TDV-553	
• Minimum spacer thickness: 40 µ	Philips LVP04.15 min spacer	
• Maximum spacer thickness: 70 µ	Philips LVP04.15 max spacer	
• Marginal Reflection L0 14% ~ 17%, L1 > 25% Reflection L0 > 15%, L1 14% ~ 17%	Philips LVP12.01 Philips LVP12.02	
DVD+R		
• Black dot: 1000 µ	TDV-PR525CW	
• Normal Fingerprint: 65 µ	Philips HAC10R TDV-PR525CW	
• Heavy Fingerprint: 75 µ	TDV-PR525CW	
• Scratch: 3mm	HAC5RS TDV-PR521CW	
• Vertical deviation: _0.5mm	TDV-PR533CW	
• Eccentricity: 150 µ	TDV-PR513CW	
DVD+RW		
• Black dot: 1000 µ	TDV-PW525CW	
• Normal Fingerprint: 65 µ	Philips HAC11 TDV-PW525CW	
• Heavy Fingerprint: 75 µ	TDV-PW525CW	
• Scratch: 3mm	HAC5S TDV-PW521CW	
• Vertical deviation: _0.5mm	TDV-PW533CW	
• Eccentricity: 150 µ	TDV-PW513CW	
• Linking error disc	Philips NLT01/02	
DVD-R		
• Black dot: 1000 µ	TDV-R525CW	
• Normal Fingerprint: 65 µ	TDV-R525CW	
• Heavy Fingerprint: 75 µ	TDV-R525CW	

• Scratch: 3mm	TDV-R521CW	
• Vertical deviation: $_0.5\text{mm}$	TDV-R533CW	
• Eccentricity: $150\ \mu$	TDV-R513CW	
DVD-RW		
• Black dot: $1000\ \mu$	TDV-MW525CW	
• Normal Fingerprint: $65\ \mu$	TDV-MW525CW	
• Heavy Fingerprint: $75\ \mu$	TDV-MW525CW	
• Scratch: 3mm	TDV-MW521CW	
• Vertical deviation: $_0.5\text{mm}$	TDV-MR533CW	
• Eccentricity: $150\ \mu$	TDV-MW513CW	
BD-ROM & BD-R(E)		
• Black dot: $1100\ \mu$ ($1000\ \mu$)	OM&T 05131 (BD-ROM DL) OM&T 03151 (BD-RE) OM&T 04131 (BD-R DL)	TBM2-A2-DF1 (BD-ROM DL) TBE-V2-DF1 (BD-RE) TBR2-V3-DF1 (BD-R DL)
• Black band: $1100\ \mu$ ($1000\ \mu$)	OM&T 05121 (BD-ROM DL) OM&T 03141 (BD-RE) OM&T 04121 (BD-R DL)	TBM2-A2-BF1 (BD-ROM DL) TBE-V2-BF1 (BD-RE) TBR2-V3-BF1 (BD-R DL)
• Double black dot: $600\ \mu + 300\ \mu$	812245001211 (BD-ROM) 812245000811 (BD-RE) 812245000991 (BD-R)	
• Normal fingerprint: $16\ \mu$	OM&T 05131 (BD-ROM DL) OM&T 03151 (BD-RE) OM&T 04131 (BD-R DL)	TBM2-A2-DF1 (BD-ROM DL) TBE-V2-DF1 (BD-RE) TBR2-V3-DF1 (BD-R DL)
• Heavy fingerprint: $18\ \mu$	OM&T 05201 (BD-ROM DL) OM&T 03011 (BD-RE) OM&T 04201 (BD-R DL)	TBM2-A2-F2 (BD-ROM DL) TBE-V2-F1 (BD-RE) TBR2-V3-F1 (BD-R DL)
• Scratch: 2mm (2.1mm)	OM&T 05191 (BD-ROM DL) OM&T 03211 (BD-RE) OM&T 04191 (BD-R DL)	TBM2-A2-S3 (BD-ROM DL) TBM2-V2-S3 (BD-RE) TBR2-V3-S3 (BD-R DL)
• Vertical deviation: $_0.6\text{mm}$	OM&T 05111 (BD-ROM DL) OM&T 03131 (BD-RE) OM&T 04111 (BD-R DL)	TBM2-A2-V6 (BD-ROM DL) TBE-V2-V6 (BD-RE) TBR2-V3-V6 (BD-R DL)
• Eccentricity: $120\ \mu$	OM&T 05071 (BD-ROM DL) OM&T 03101 (BD-RE) OM&T 04071 (BD-R DL)	TBM2-A2-R120 (BD-ROM DL) TBE-V2-R120 (BD-RE) TBR2-V3-R120 (BD-R DL)
• SL min cover layer: $95\ \mu$	SONY BLX-301	Covr Layer $95\pm 1\ \mu\text{m}$ thick
• SL max cover layer: $105\ \mu$	SONY BLX-302	Covr Layer $105\pm 1\ \mu\text{m}$ thick
• DL min cover layer: $70\ \mu$	SONY BLX-303	Covr Layer (TS1) $70\pm 1\ \mu\text{m}$ thick
• DL max cover layer: $80\ \mu$	SONY BLX-304	Covr Layer (TS1) $80\pm 1\ \mu\text{m}$ thick
• DL min spacer: $20\ \mu$	SONY BLX-305	Spacer Layer $23\pm 1\ \mu\text{m}$ thick
• DL max spacer: $30\ \mu$	SONY BLX-306	Spacer Layer $30\pm 1\ \mu\text{m}$ thick
• BD-ROM SL high reflection: 70%	SONY BLX-307	Reflectivity $65\pm 1\%$
• BD-ROM DL high reflection: 28% (for L0)	SONY BLX-312	Reflectivity $27\pm 1\%$ (L0), $13\pm 1\%$ (L1)
• BD-ROM SL low reflection: 35%	SONY BLX-309	Reflectivity $35\pm 1\%$
• BD-ROM DL low reflection: 12% (for L0)	SONY BLX-311	Reflectivity $13\pm 1\%$ (L0), $27\pm 1\%$ (L1)
• BD-R(E)(ROM) Hair scratch: Light	OM&T 05141 (BD-ROM DL) OM&T 03161 (BD-RE) OM&T 04141 (BD-R DL)	TBM2-A2-S1 (BD-ROM DL) TBE-V2-S1 (BD-RE) TBR2-V3-S1 (BD-R DL)
• BD-R(E)(ROM) Hair scratch: Normal	OM&T 05151 (BD-ROM DL) OM&T 03171 (BD-RE) OM&T 04151 (BD-R DL)	TBM2-A2-S2 (BD-ROM DL) TBE-V2-S2 (BD-RE) TBR2-V3-S2 (BD-R DL)
• BD-ROM SL/DL unbalance: 7gmm	OM&T 01741 (BD-ROM SL) OM&T 05031 (BD-ROM DL)	TBM-A1-B70 (BD-ROM SL) BM2-A2-B70 (BD- ROM DL)
• BD-R(E) SL/DL unbalance: 7gmm	OM&T 03051 (BD-RE SL) OM&T 04031 (BD-R DL) OM&T 02551 (BD-R SL)	TBE-V2-B70 (BD-RE SL) TBR2-V3-B70 (BD-R DL) TBR-V2-B70 (BD-R SL)
Others		
Dual Disc	Commercial disc	Playback both CD & DVD side

Service Hints

CAUTION

CHARGED CAPACITORS ON THE SERVO BOARD MAY DAMAGE THE DRIVE ELECTRONICS WHEN CONNECTING A NEW DRIVE. THAT'S WHY, BESIDES THE SAFETY MEASURES LIKE

- **SWITCH OFF POWER SUPPLY**
- **ESD PROTECTION**

ADDITIONAL ACTIONS MUST BE TAKEN BY THE REPAIR TECHNICIAN.

The following steps have to be done when replacing the defective loader :

1. Dismantling of the loader to access the ESD protection point if necessary.
2. **Solder the ESD protection point***.
3. Disconnect flexfoil cable from the defective loader.
4. Put a paper clip on the flexfoil to short-circuit the contacts (fig.1)
5. Replace the defective loader with a new loader.
6. Remove paperclip from the flexfoil and connect it to the new loader.
7. Remove solder joint on the ESD protection point.

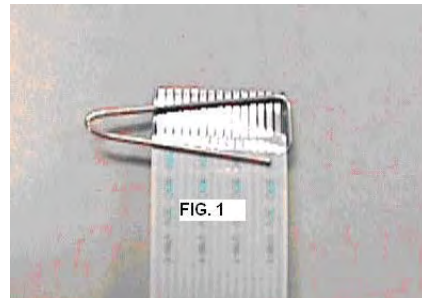

ATTENTION: The laser diode of this loader is protected against ESD by a solder joint which shortcircuits the laserdiode to ground. For proper functionality of the loader this solder joint must be remove **after** connection loader to the set.

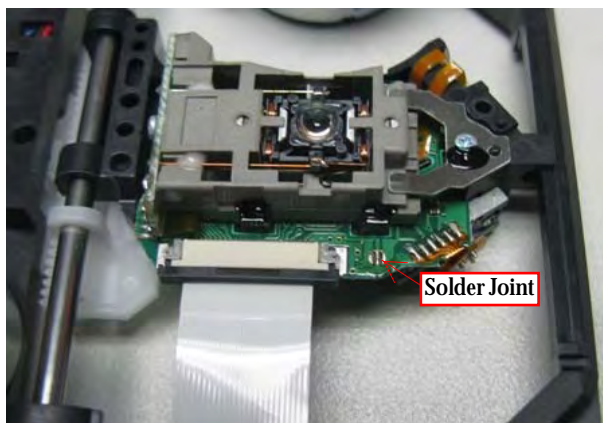

(ESD protection point is accessible from top of loader)

****Only applicable for defective loader needed to be sent back to supplier for failure analysis and to support backcharging evidence.***

This is also applicable for all partnership workshops.

Software check and upgrade

Preparation to Software Upgrade

1. Procedure for software upgrade

a) Upgrade from USB:

- 1)Go to www.philips.com/support to check if the latest software version is available for this player.
- 2)Build UPG file in USB
- 3)Copy the upgrade file to USB UPG folder.
- 4)Then insert USB,start up DUT enter into HOME screen ,select Setup >>Advance>> software update >>USB.
- 5)When upgrade file detected, select "Yes" to upgrade, select "No" to cancel.
- 6)Once you start upgrade, please don't power off the DUT, after upgrade DUT will restart up later a moment time.

b) Upgrade software via network: (only support BDP2300/2305/2385,NOT support BDP2110/2190)

- 1) 1) Setup the network connection.
- 2) start up DUT enter into HOME screen ,select Setup >>Advance>> software update >>Network
 - * You are prompted to start upgrading processes if upgrade media is detected.
- 3)Follow the instructions on the TV screen to confirm update operation.
- 4)When upgrade file download completed, select "Start" to upgrade.
- 5) Once you start upgrade, pls don't power off the DUT, after upgrade DUT will restart up later a moment time.

Checked the version information after upgraded.

Wake up DUT, select Setup >>Advance>>version information . You will see a interface as below:

Model:BDPXXXX/XX
 Software Version:
 System SW:X.XX
 Ethernet :XX:XX:XX:XX:XX:XX
 Wireless(WI-FI): XX:XX:XX:XX:XX:XX (if support built-in WIFI)
 For information, frequently asked questions and software updates,
 visit www.philips.com/support.

Close

Factory ResetSteps

Wake up DUT and select Setup >>Advance>>Restore default setting, Press ok button Then the DUT will reboot if restore default setting succeeded.

No light on LED, and buttons do not work

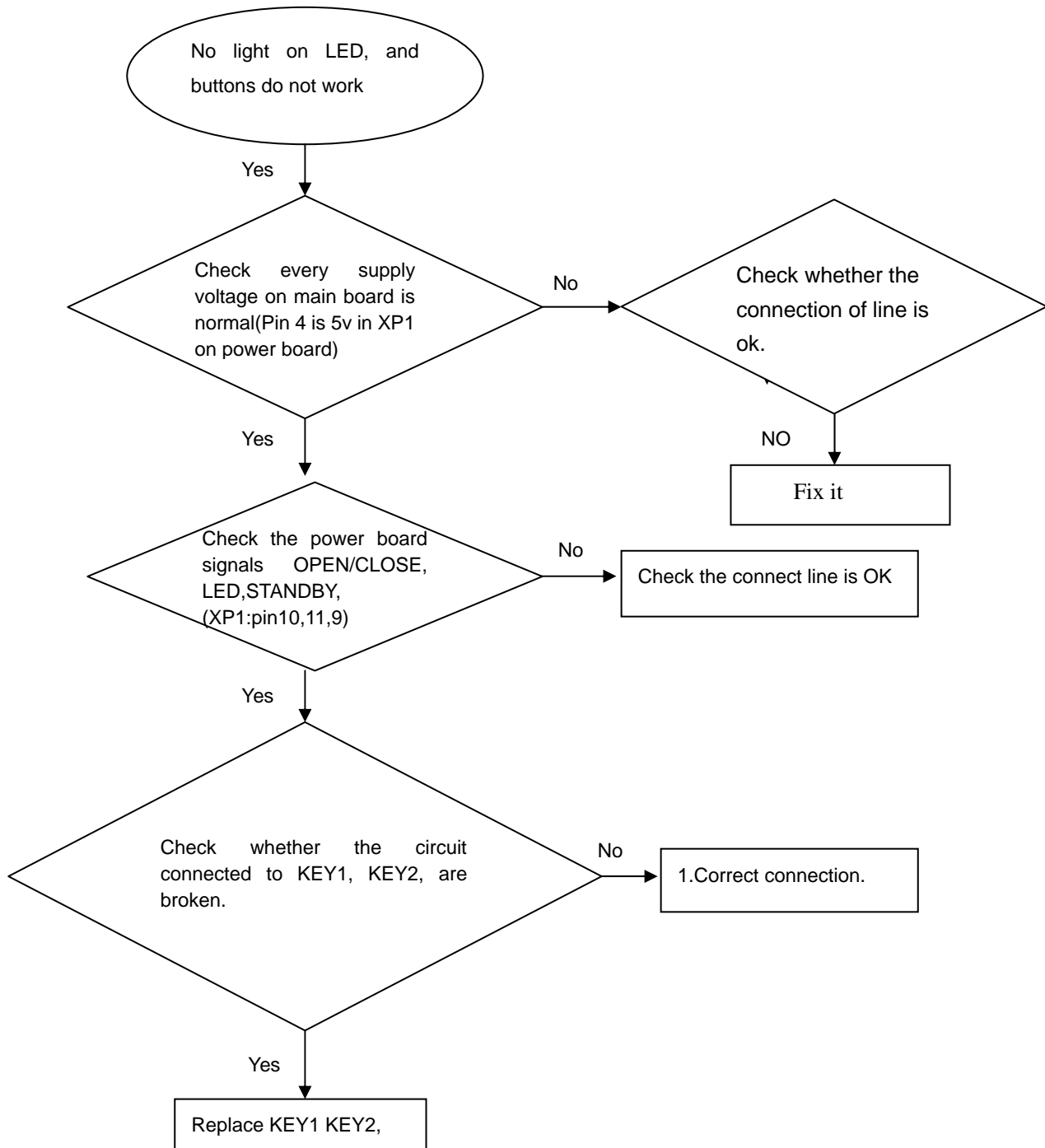

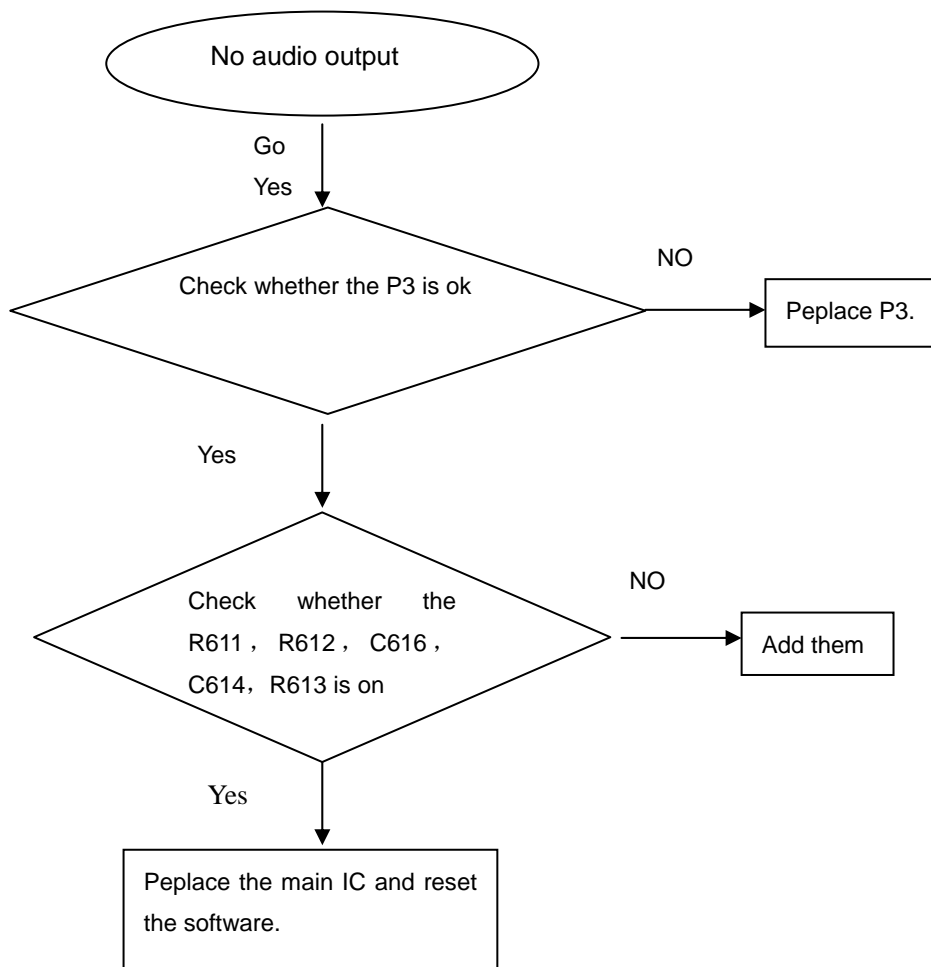
No audio output

Remote control does not work

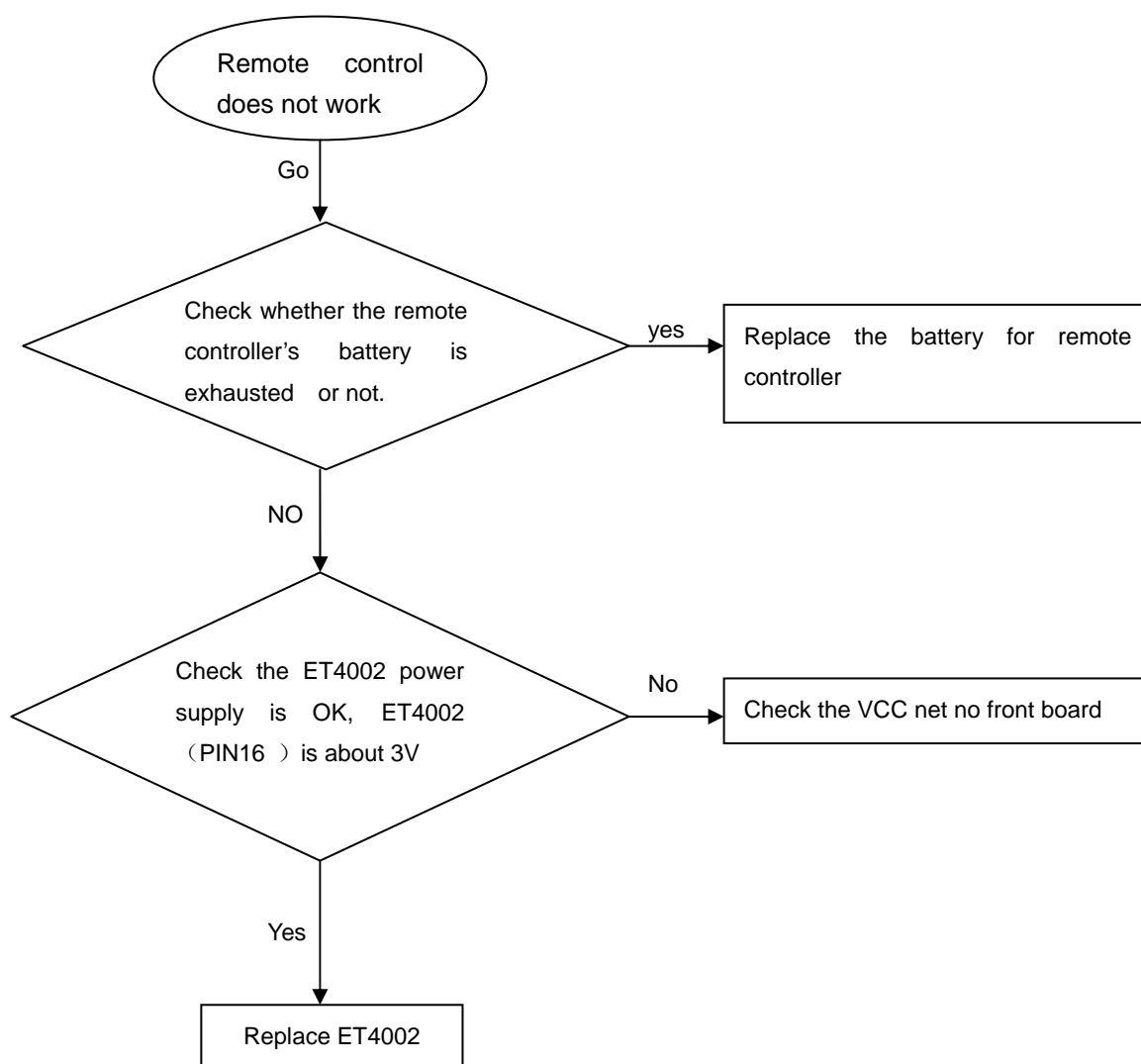

Can't read disc or can't open the disk door

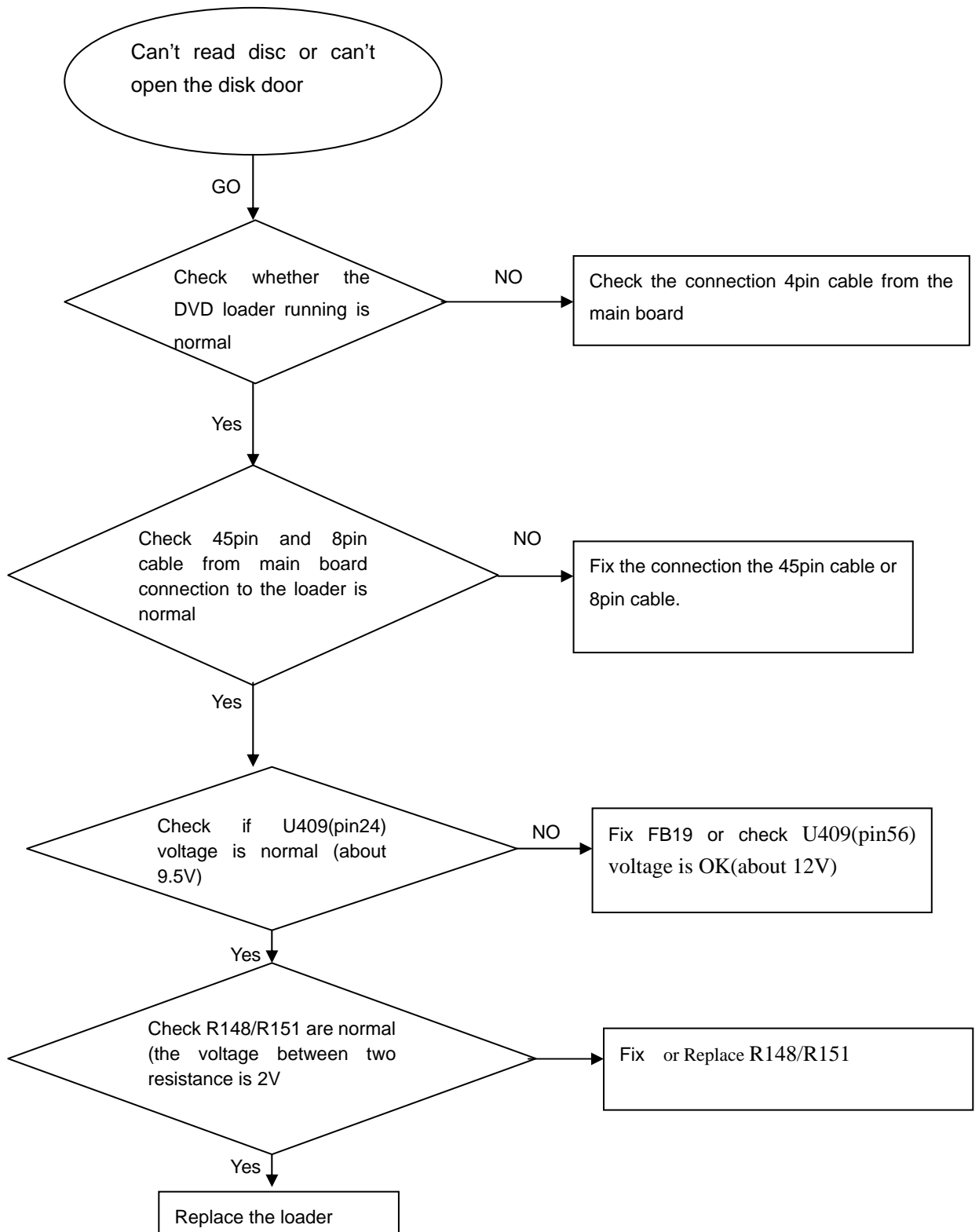

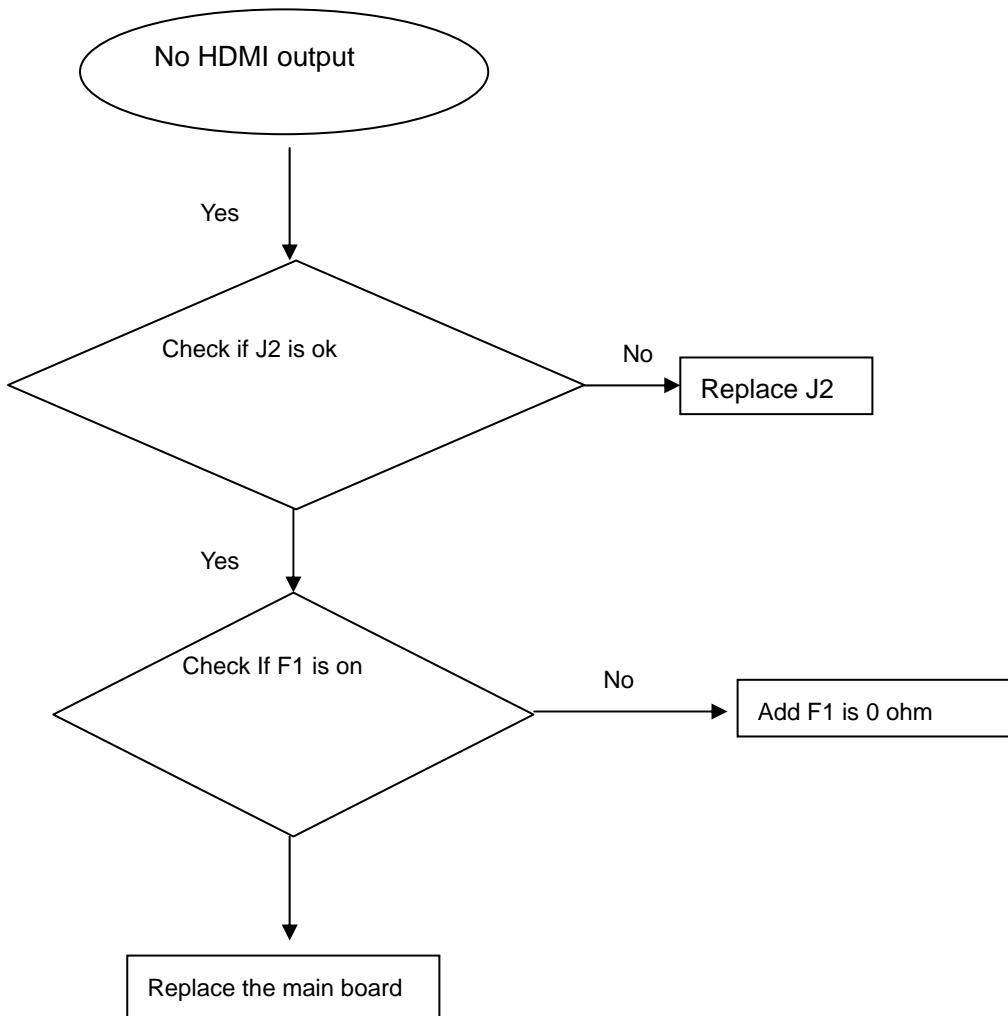
No HDMI output

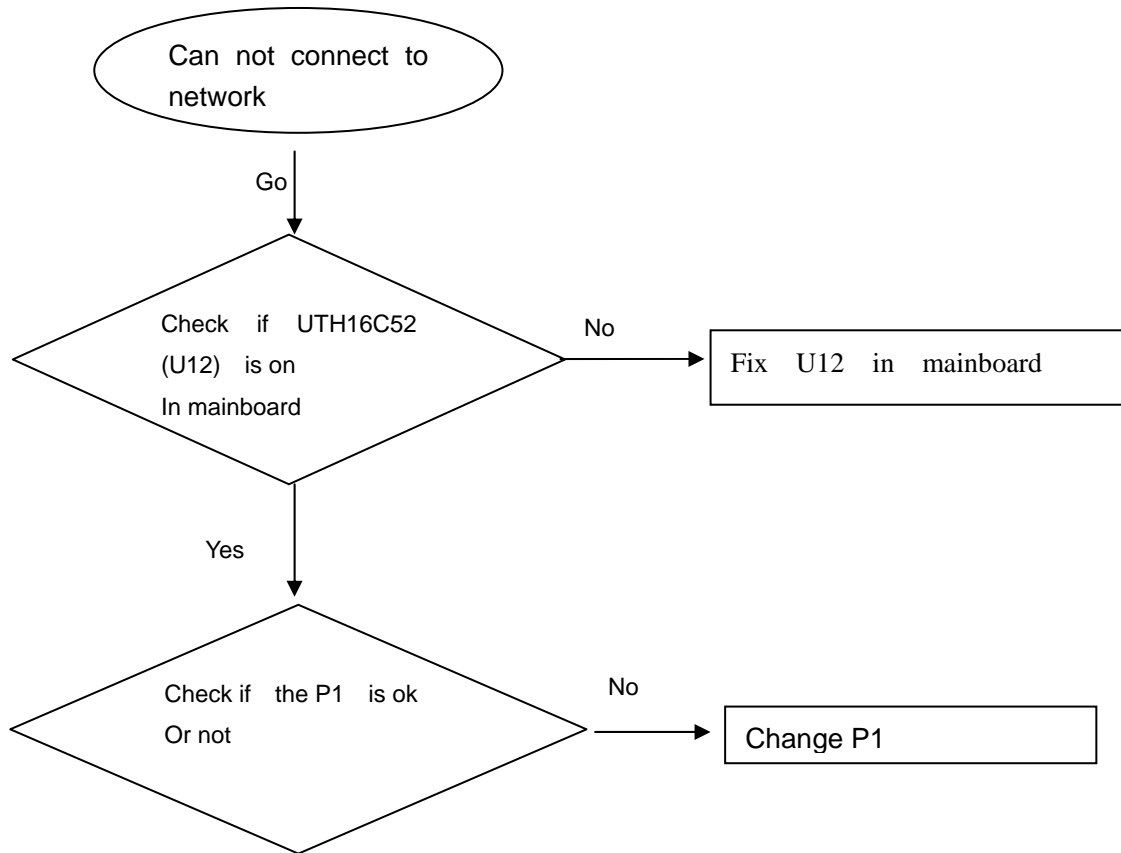
Can not connect to network

Can not connect to WIFI

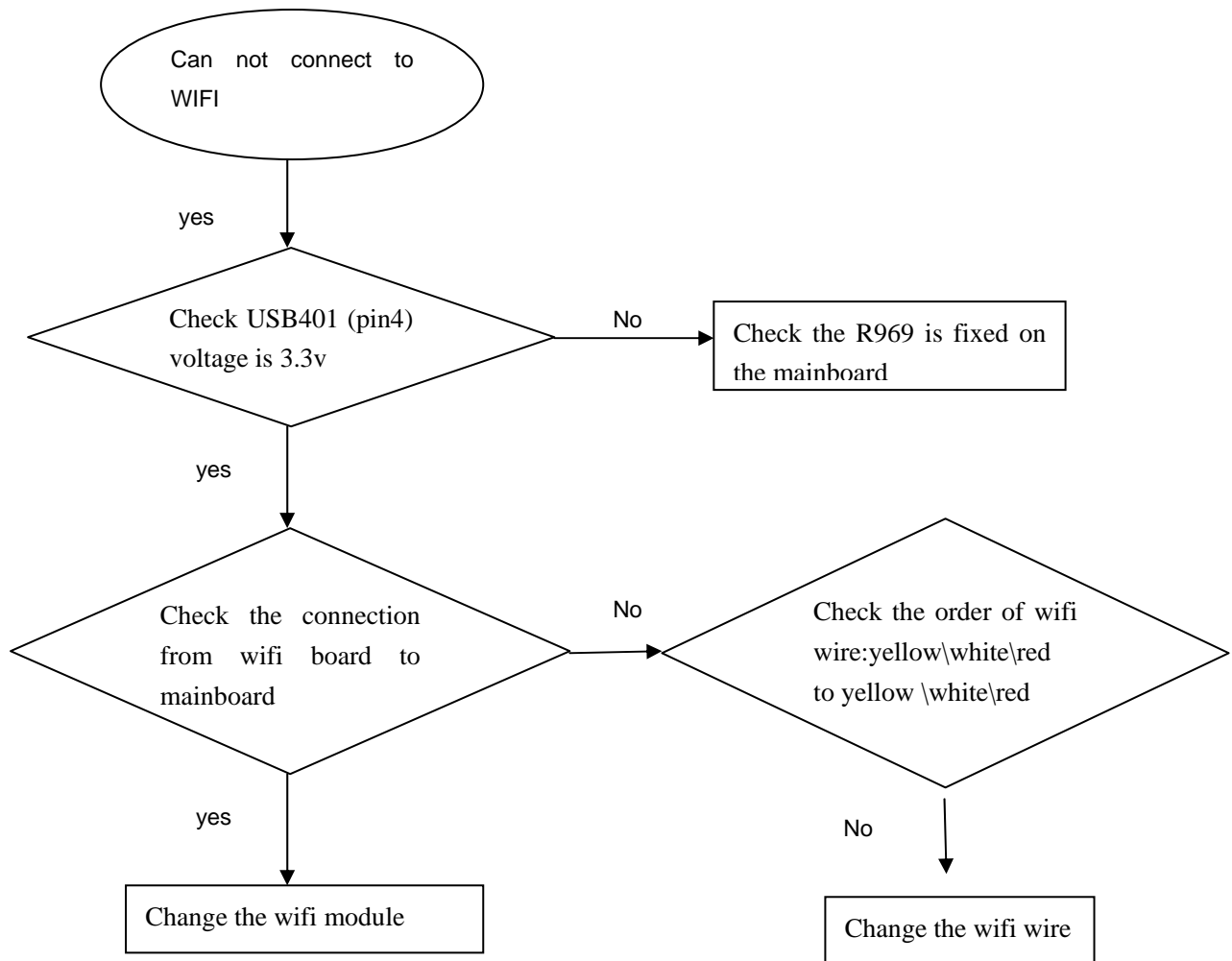

Mechanical and Dismantling Instructions

Dismantling Instruction

Detailed information please refer to the model set.

The following guidelines show how to dismantle the player.

Step1:Open the top cover. Remove 2 screws on the back panel ,then open the top cover.



Step2: Dismantle the front panel .Connect power and boot,than open the tray . And than pull up the front panel



Step3 Dismantle the Loader.Remove 2 screws baside the Loader.
Than disconnect 3 connectors beside the loader



Mechanical and Dismantling Instructions

Dismantling Instruction

Detailed information please refer to the model set.

The following guidelines show how to dismantle the player.

Step4: Dismantle the PF board. Remove the screw on the wireless board and disconnect the connector, then pull up the wireless board. And then remove 2 screws on the PF board



Step5: Dismantle the main board. Remove 2 screws on the back panel.



Block Diagram:

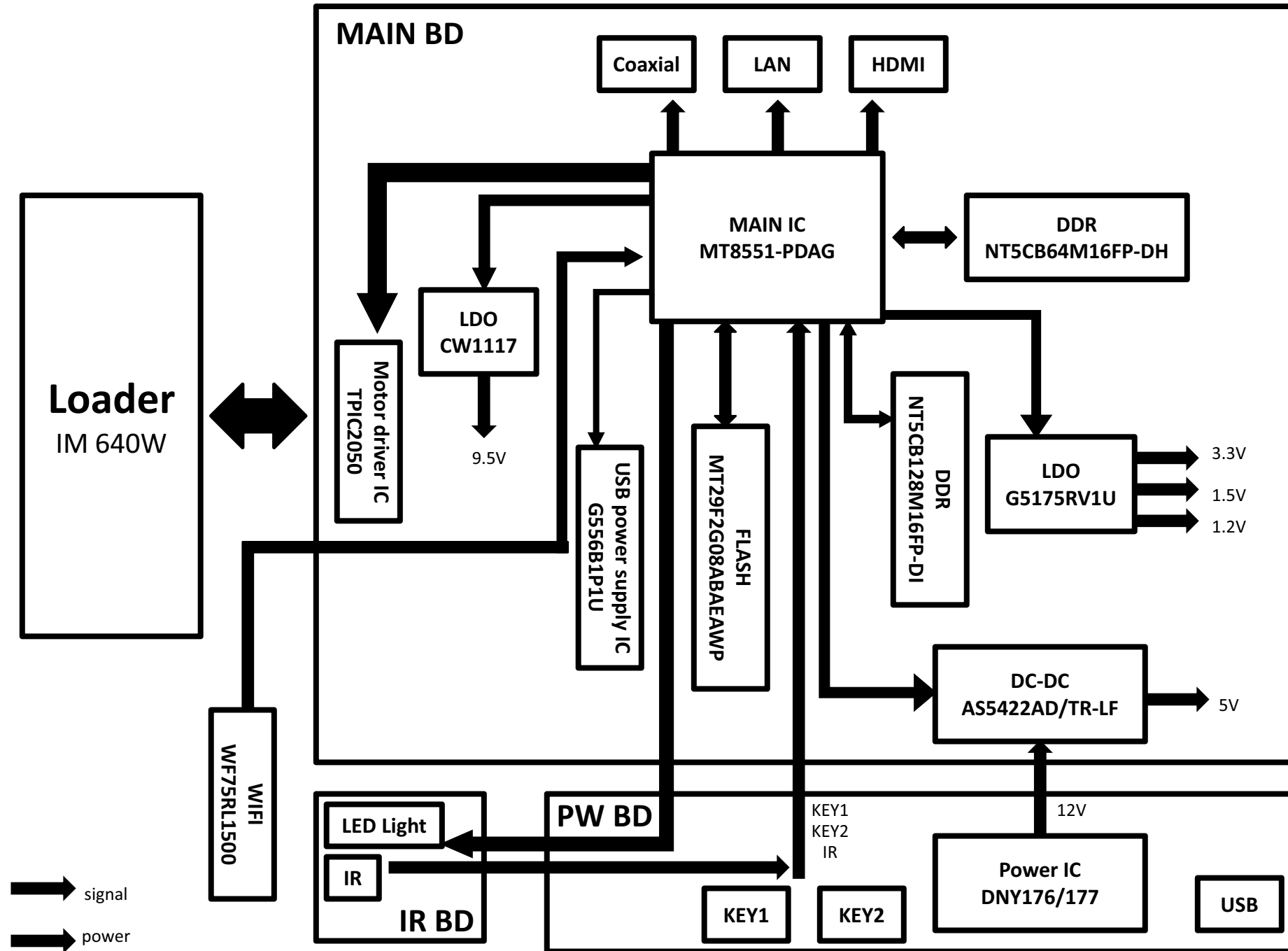

Wiring Diagram:

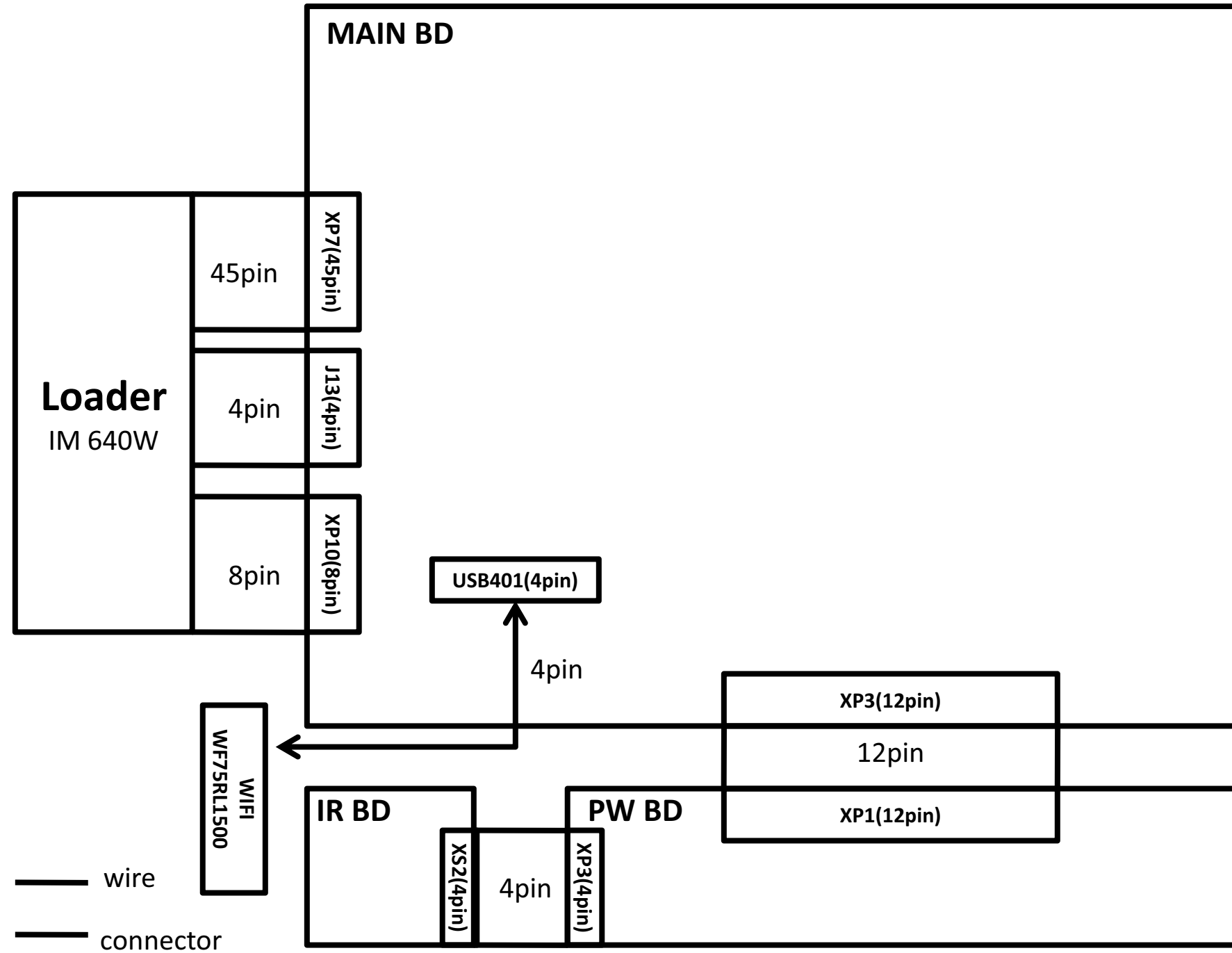

Circuit Diagram- Main Board:

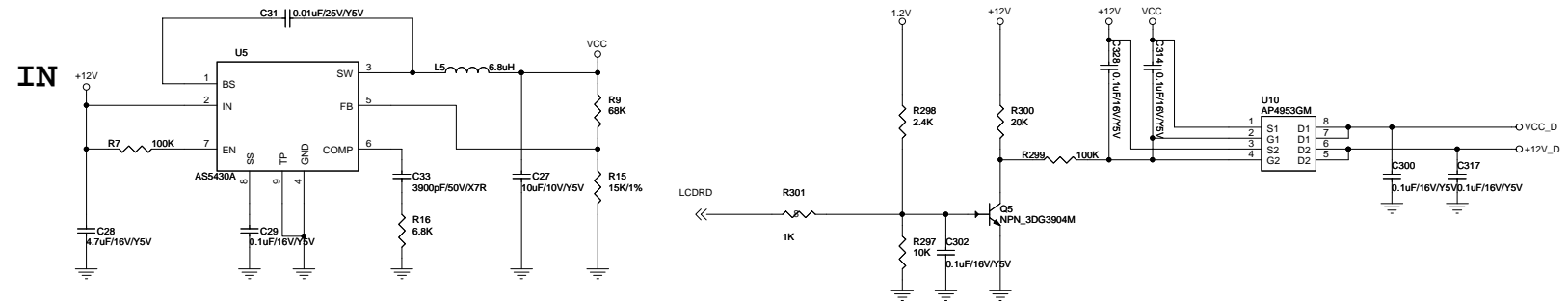
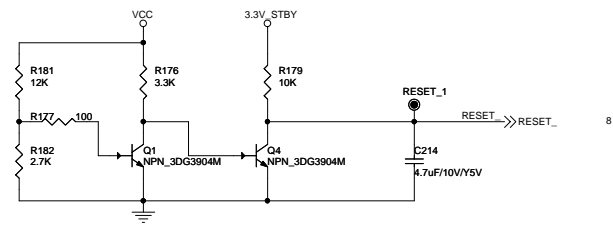
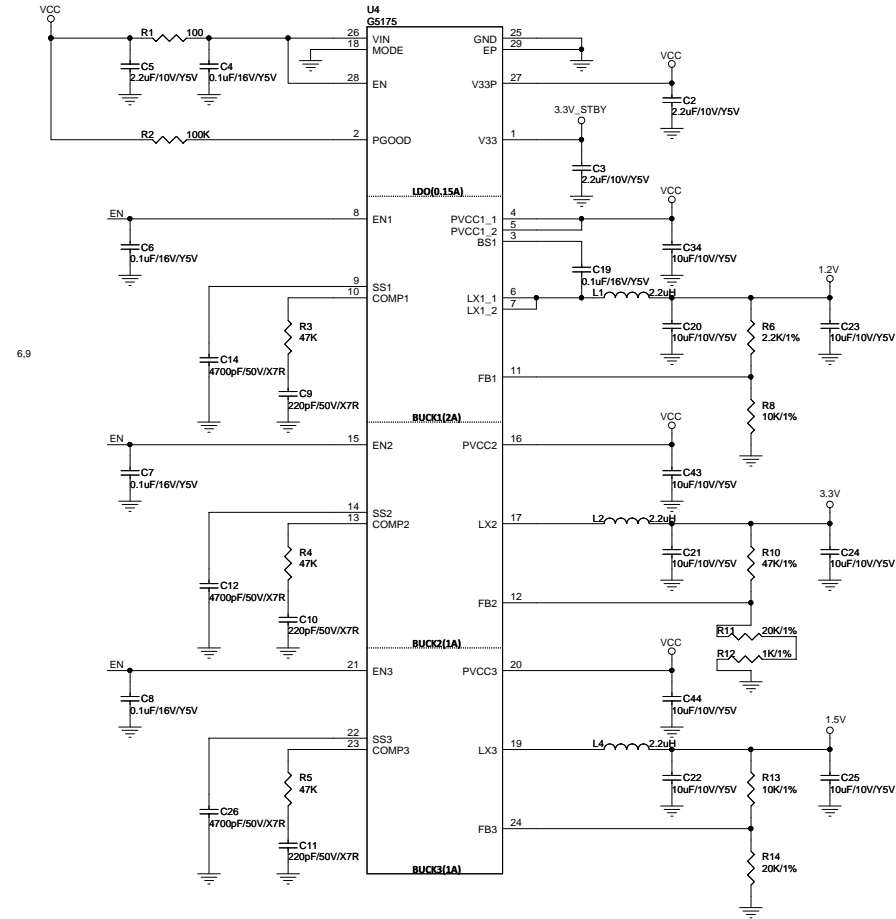
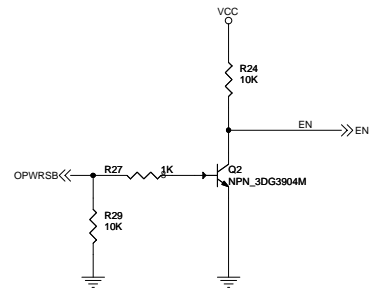

Circuit Diagram- Main Board:

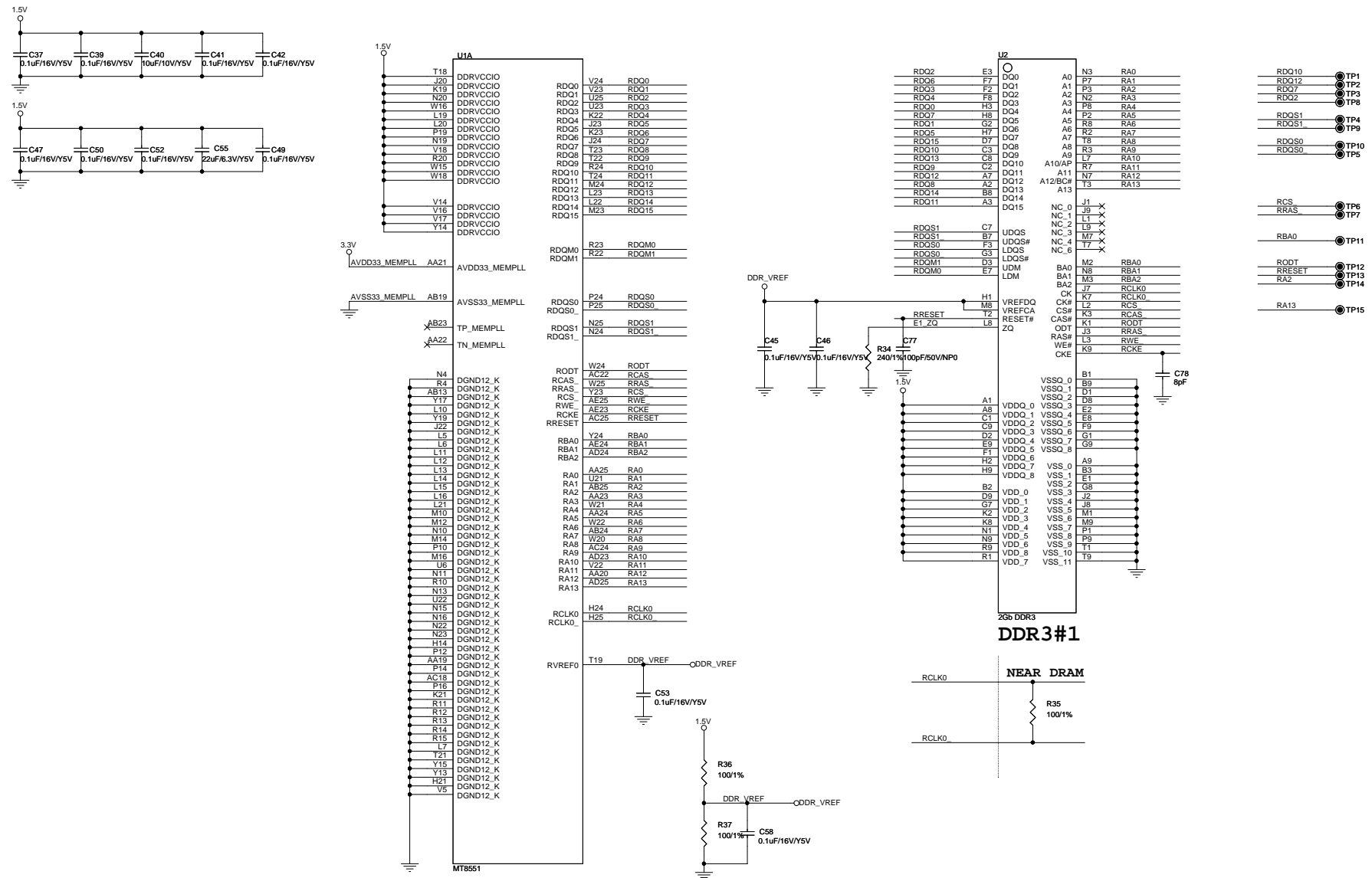

Circuit Diagram- Main Board:

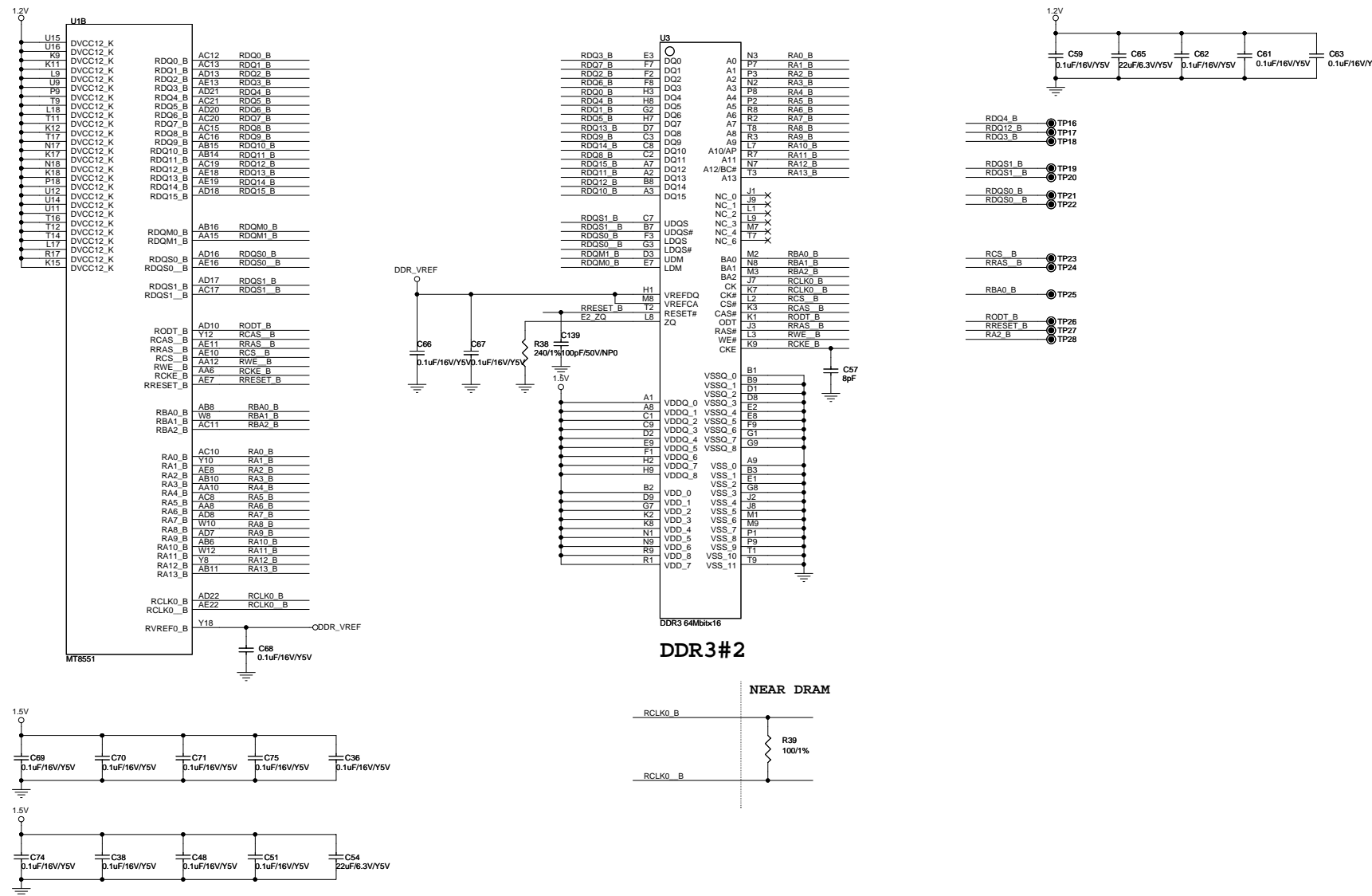

Circuit Diagram- Main Board:

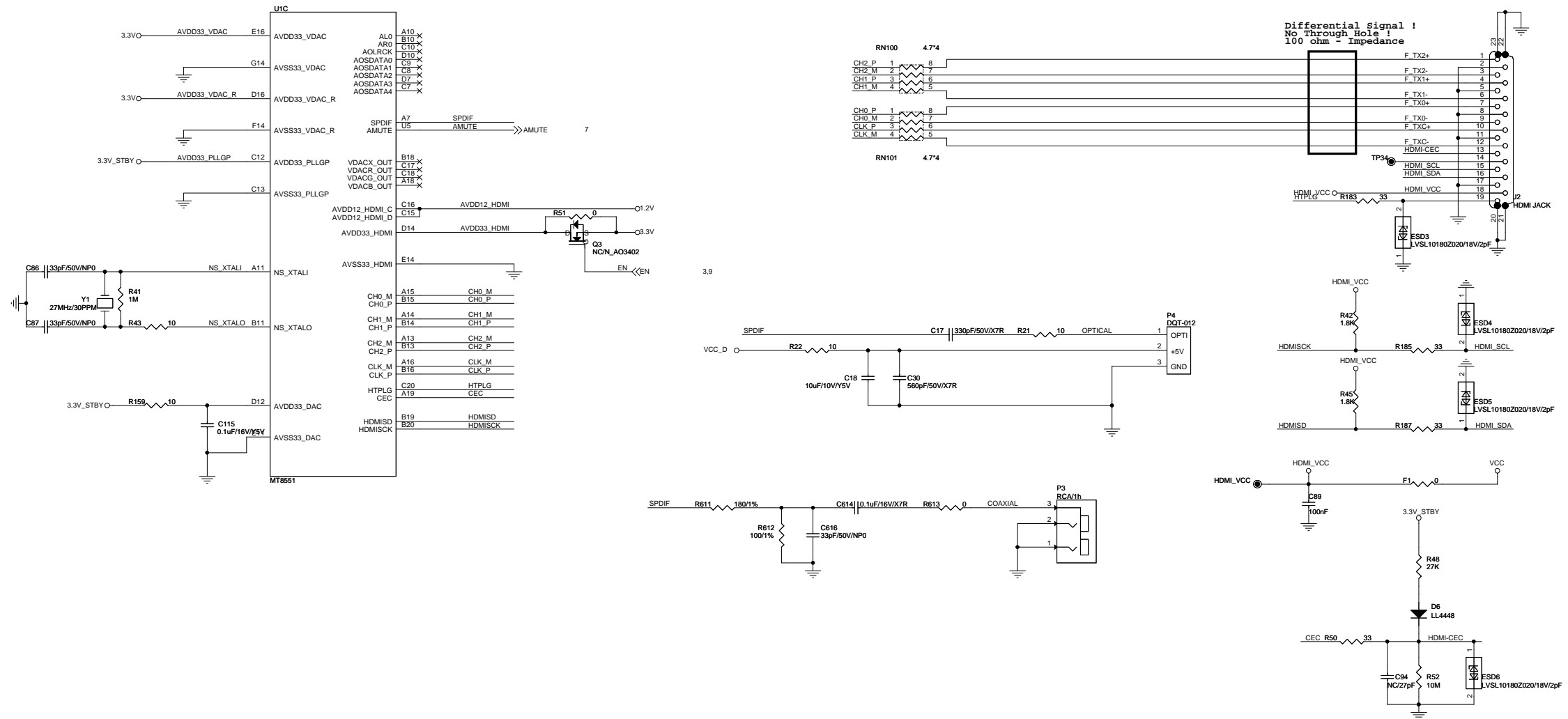

Circuit Diagram- Main Board:

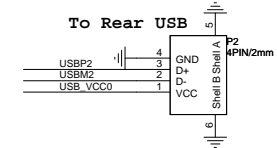
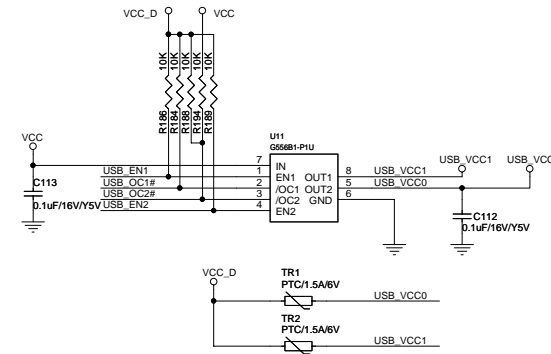
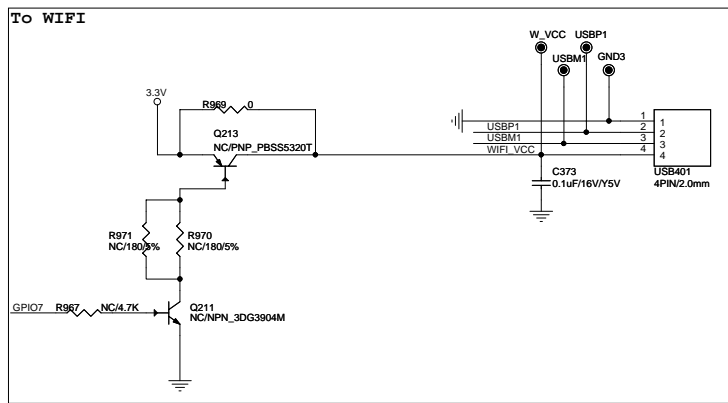
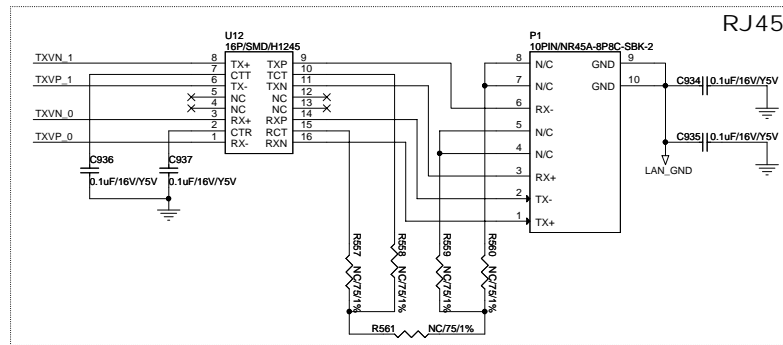
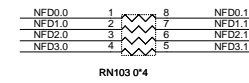
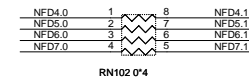
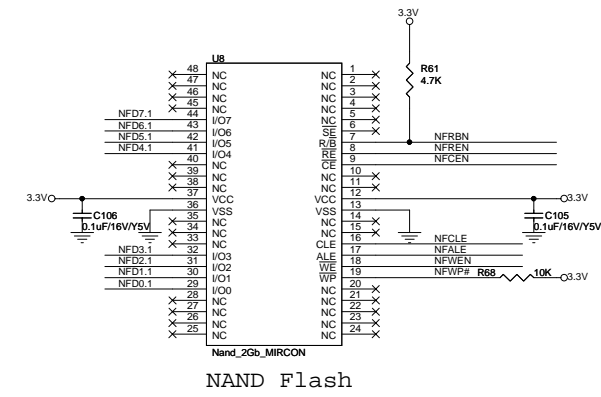
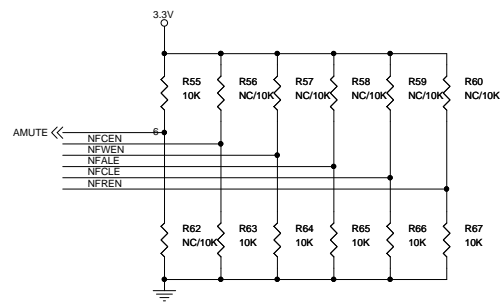
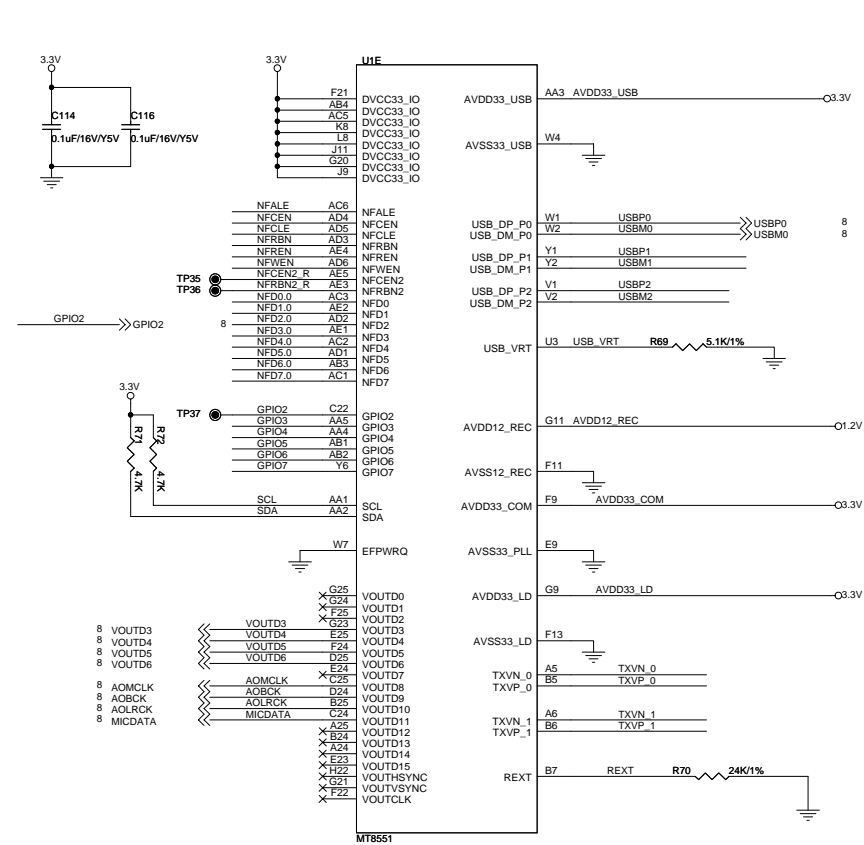

Circuit Diagram- Main Board:

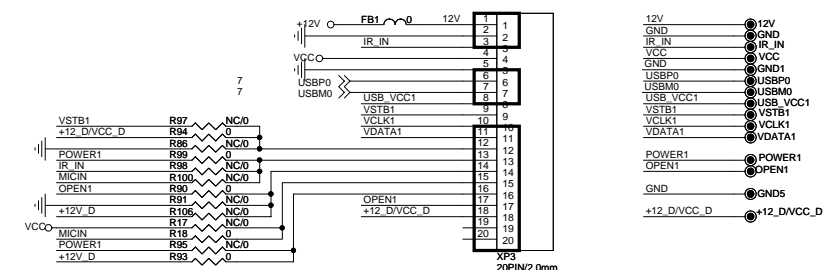
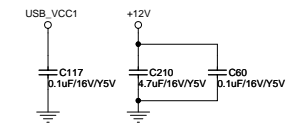
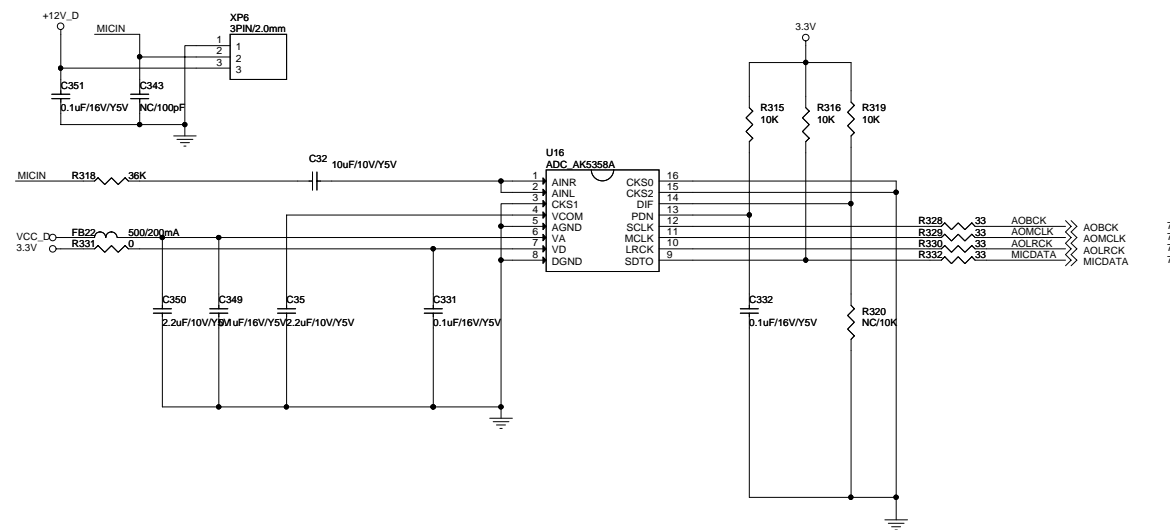
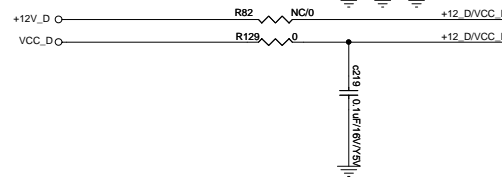
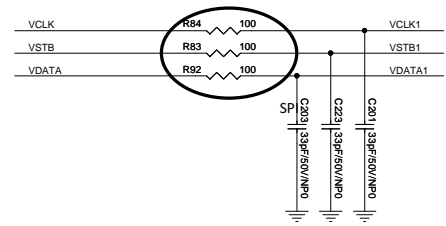
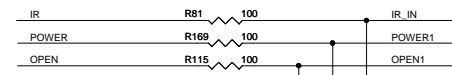
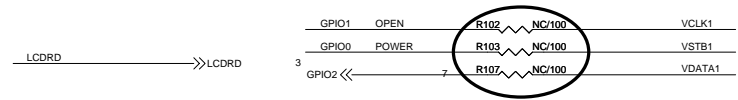
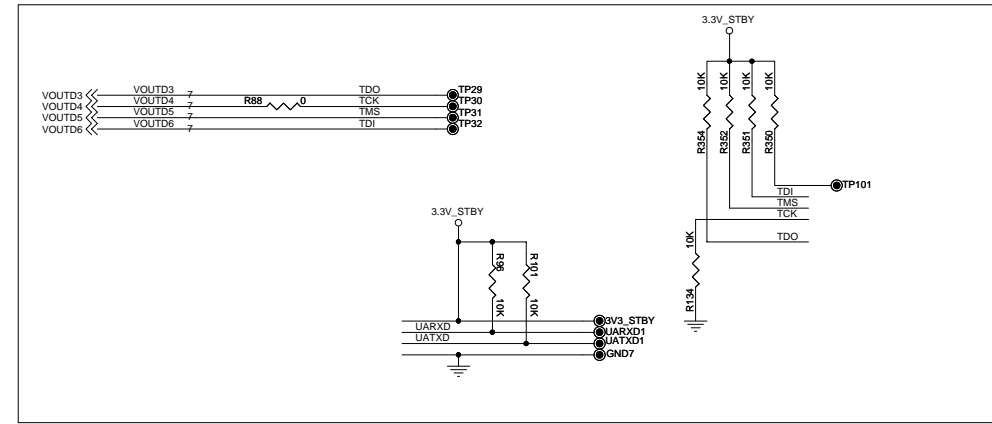
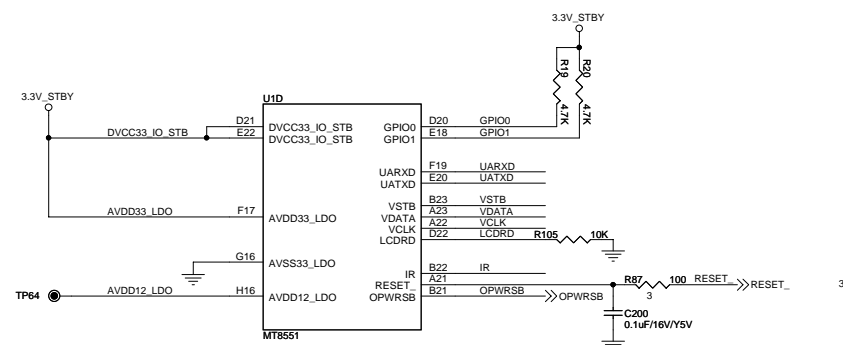

Circuit Diagram- Main Board:

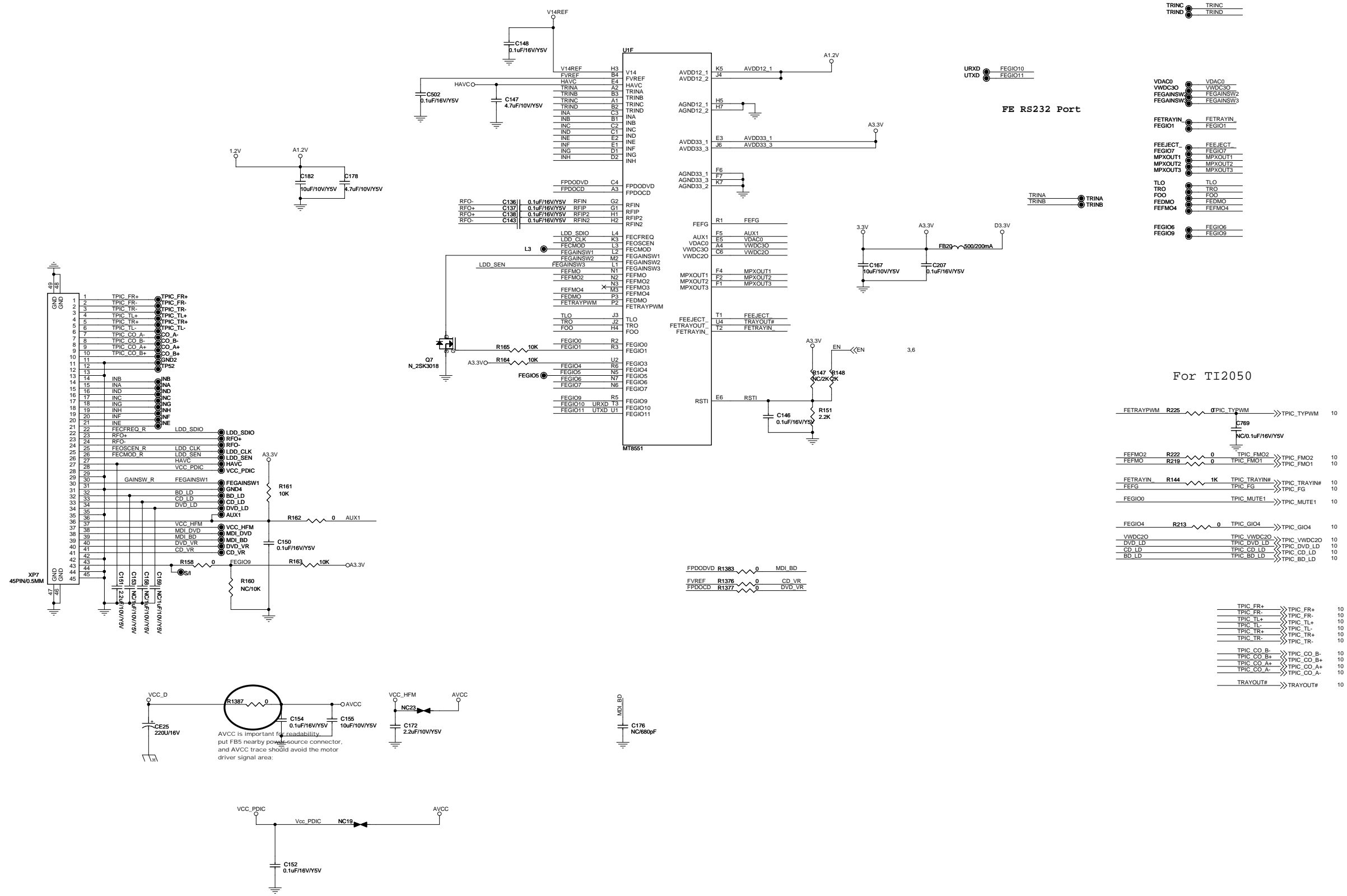

Circuit Diagram- Main Board:

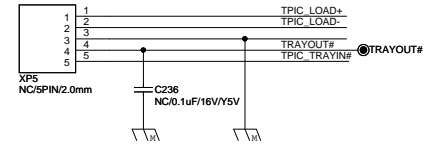
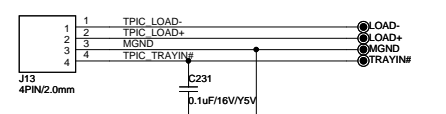
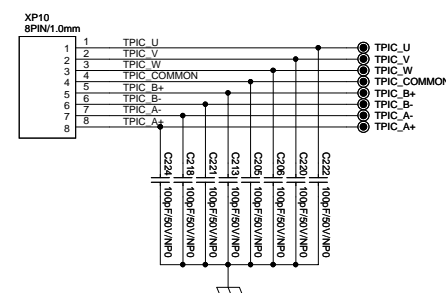
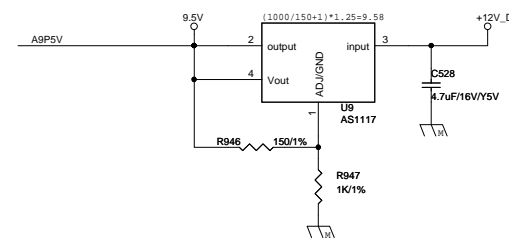
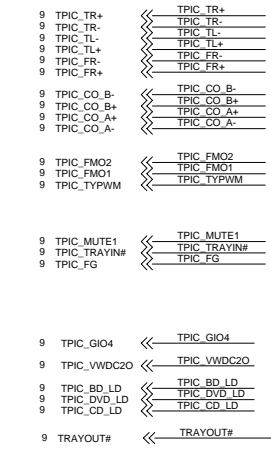
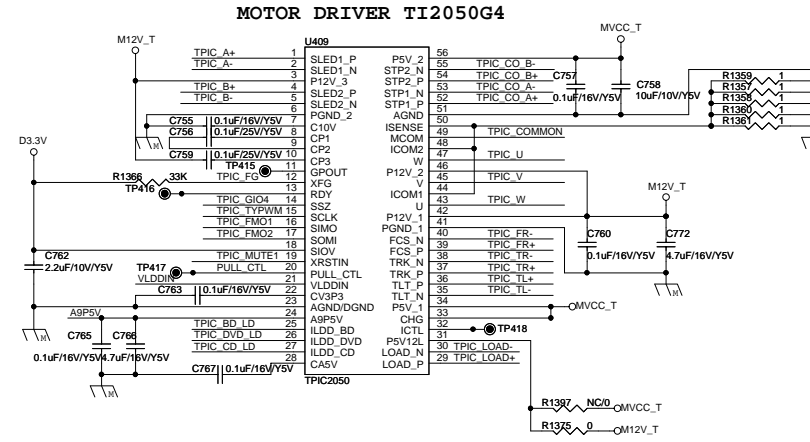
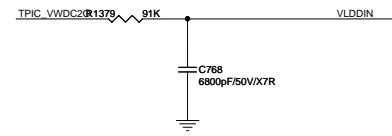
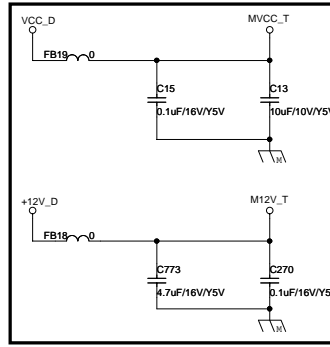

Circuit Diagram- PF Board:

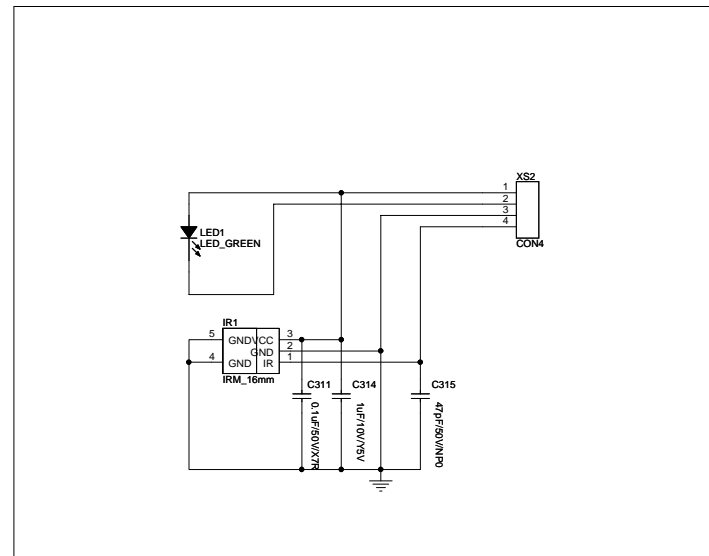

Circuit Diagram- PF Board:

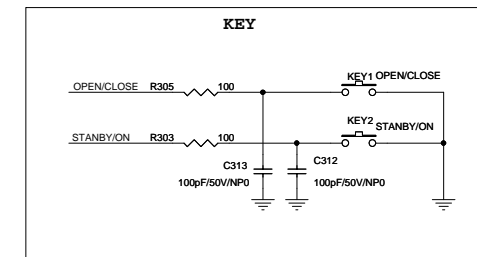
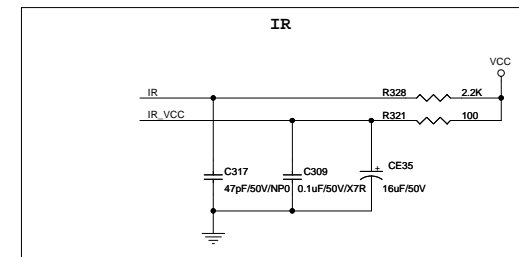
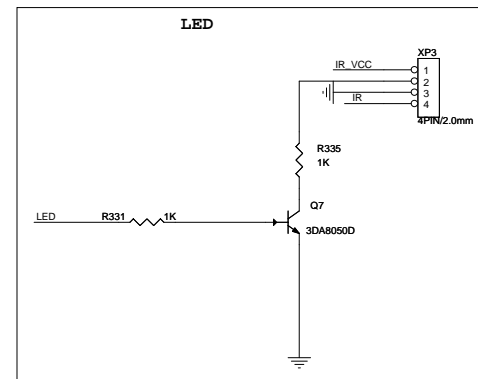
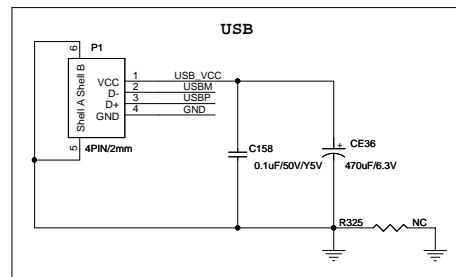
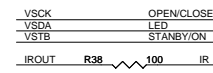
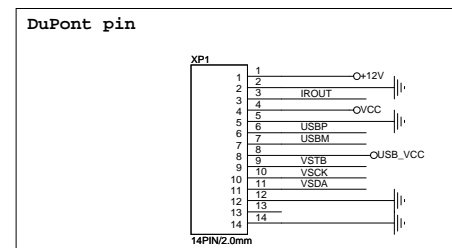

Circuit Diagram- PF Board:

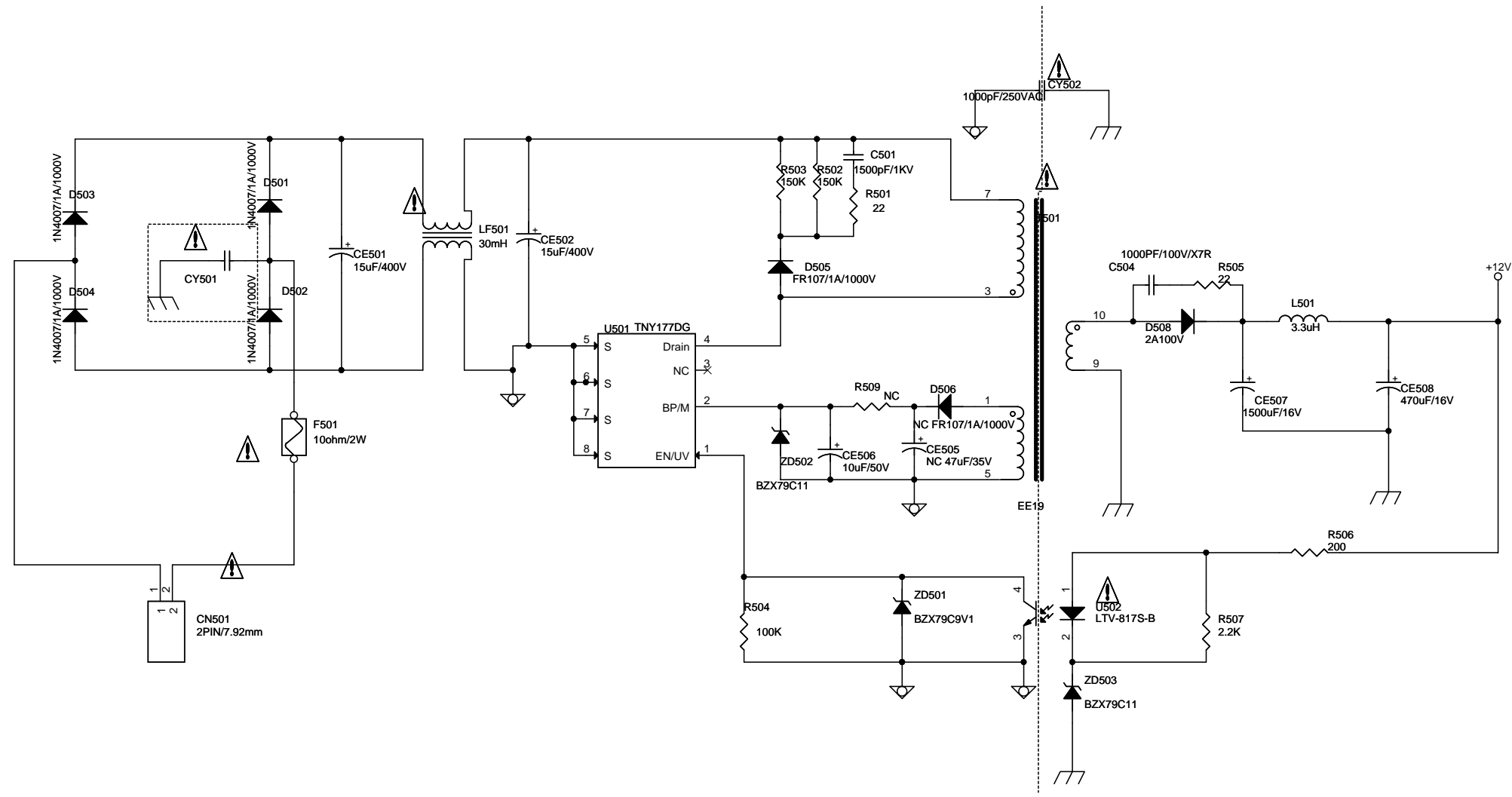

Print Layout-Main Board(top):

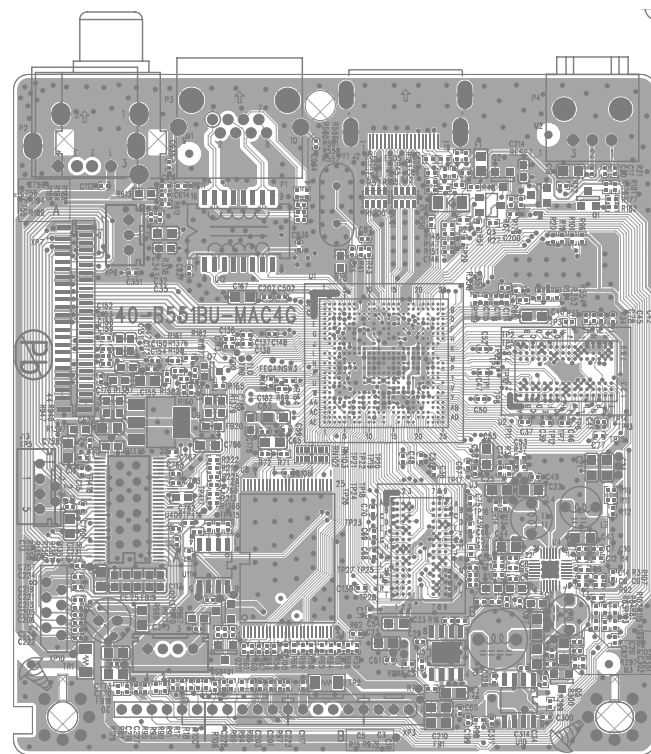

Print Layout-Main Board(bottom):

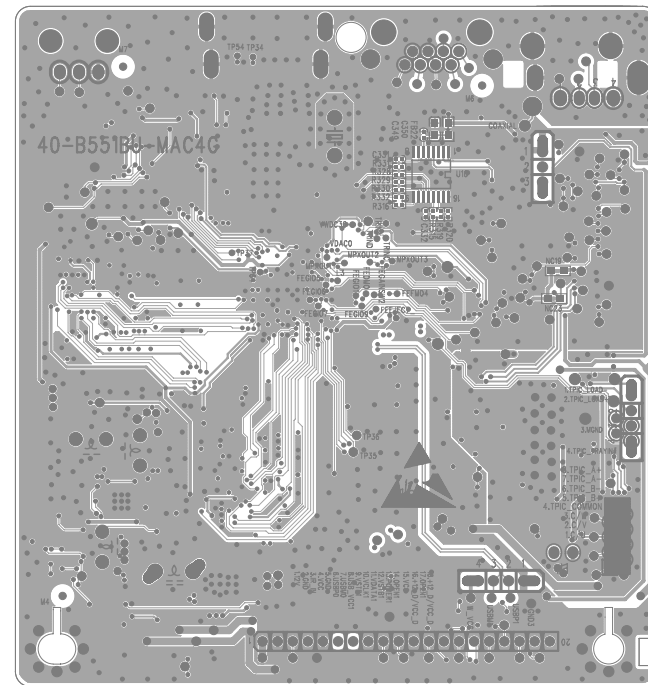

Print Layout-PF Board:

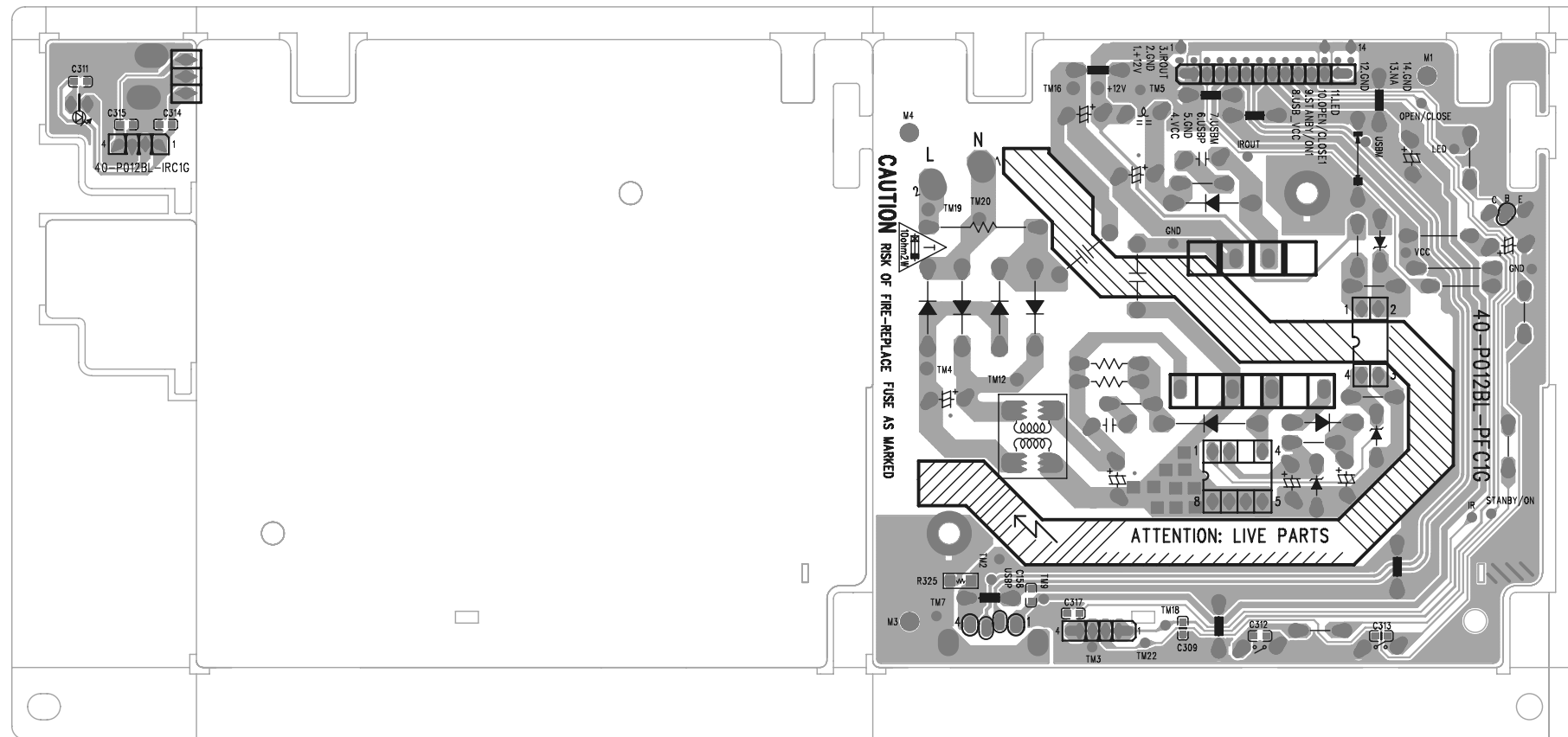

Exploded View:

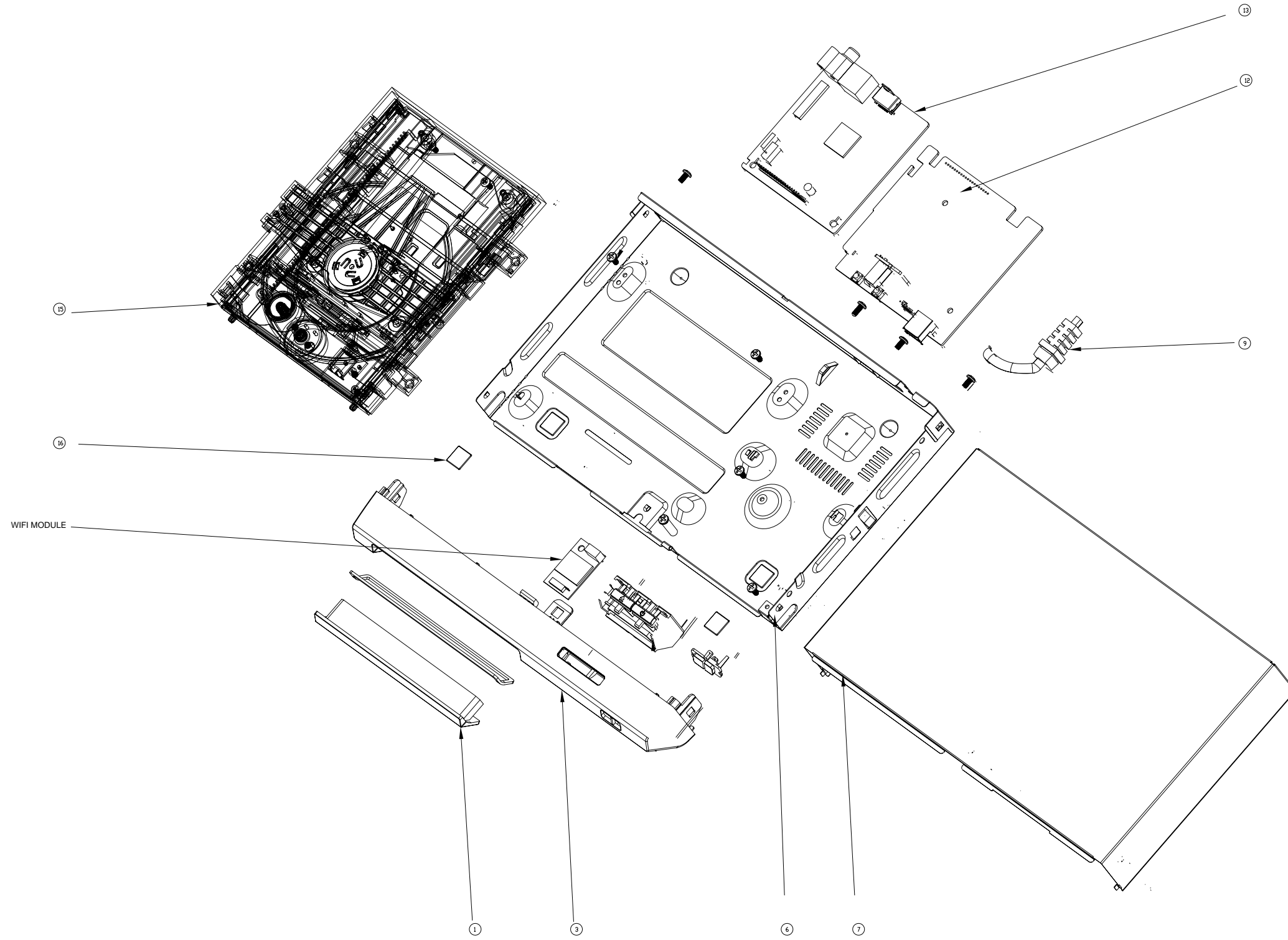

REVISION LIST

V 1.0 2014-12-29 Initial release for BDP2305/F7 .

V 1.1 2015-1-8 Initial release for BDP2305/ 12

V1.2 2015-1-8 Initial release for BDP2305X/ 77